

Panasonic[®]

Installation Manual

Additional Cordless Handset

Model No. **KX-TGUA40**



Thank you for purchasing a Panasonic product.

You must register this handset with your base unit before it can be used. This installation manual describes only the steps needed to register and begin using the handset. Please read the base unit's operating instructions for further details.

Please read this installation manual before using the unit and save it for future reference.

For assistance, visit our Web site: <https://shop.panasonic.com/support> for customers in the U.S.A.



PNQX9282ZA

Accessory information

Supplied accessories

Accessory item/Part number	Quantity
Charger/PNLC1098ZB	1
Rechargeable batteries*1	2
Handset cover*2/PNYNTGUA40MR	1

*1 Please read the base unit's operating instructions for replacement battery information.

*2 The handset cover comes attached to the handset.













Note:

- Please read the base unit's operating instructions for additional/replacement accessories.

Other information

- Design and specifications are subject to change without notice.
- The illustrations in these instructions may vary slightly from the actual product.
- For some features, the operations are slightly different from the descriptions in your base units operating instructions.
- Some features described in your base units operating instructions may not be available.

Graphical symbols for use on equipment and their descriptions

Symbol	Explanation	Symbol	Explanation
	Alternating current (A.C.)		Class II equipment (equipment in which protection against electric shock relies on Double Insulation or Reinforced Insulation)
	Direct current (D.C.)		"ON" (power)
	Protective earth		"OFF" (power)
	Protective bonding earth		Stand-by (power)
	Caution, risk caused by visible radiation		"ON"/"OFF" (power; push-push)
	For indoor use only		Caution, risk of electric shock

For your safety

To prevent severe injury and loss of life/property, read this section carefully before using the product to ensure proper and safe operation of your product.

WARNING

Power connection

- Completely insert the AC adaptor/power plug into the power outlet. Failure to do so may cause electric shock and/or excessive heat resulting in a fire.
- Regularly remove any dust, etc. from the AC adaptor/power plug by pulling it from the power outlet, then wiping with a dry cloth. Accumulated dust may cause an insulation defect from moisture, etc. resulting in a fire.
- Unplug the product from power outlets if it emits smoke, an abnormal smell, or makes an unusual noise. These conditions can cause fire or electric shock. Confirm that smoke has stopped emitting and contact us at <https://shop.panasonic.com/support>

Installation

- To prevent the risk of fire or electrical shock, do not expose the product to rain or any type of moisture.
- Do not place or use this product near automatically controlled devices such as automatic doors and fire alarms. Radio waves emitted from this product may cause such devices to malfunction resulting in an accident.
- Do not place the handset on the base unit when battery cover is removed.

Operating safeguards

- To prevent hearing damage, make sure anyone who uses this product is aware that the product can produce very loud sounds, and make sure children use this product only under adult supervision.
- To prevent hearing damage, we recommend that you set this product to the lowest volume setting at which you can hear adequately. Note that when the **BOOST** is displayed, the volume booster feature is enabled and the product may emit sounds at very high volume.
- Avoid prolonged exposure to loud sounds produced by this product. Be aware that the louder a sound is, the less time is needed to cause hearing damage. In the event that you experience hearing discomfort, consult a medical professional.

 **CAUTION**

Installation and location

- The AC adaptor is used as the main disconnect device. Ensure that the AC outlet is installed near the product and is easily accessible.
- The product is only use for mounting at heights ≤ 2 m.

Note:

- This height is not guaranteed for product reliability.
- To prevent serious injuries due to the product unexpectedly falling, the product must be installed at a height of 1.5 m or lower.

Battery

- We recommend using the supplied batteries or additional/replacement batteries noted on page 2 for replacement battery information. **USE ONLY rechargeable Ni-MH batteries AAA (R03) size.**
- Do not mix old and new batteries.
- Do not open or mutilate the batteries. Released electrolyte from the batteries is corrosive and may cause burns or injury to the eyes or skin. The electrolyte is toxic and may be harmful if swallowed.
- Exercise care when handling the batteries. Do not allow conductive materials such as rings, bracelets, or keys to touch the batteries, otherwise a short circuit may cause the batteries and/or the conductive material to overheat and cause burns.
- Charge the batteries provided with or identified for use with this product only, in accordance with the instructions and limitations specified in this manual.
- Only use a compatible base unit (or charger) to charge the batteries. Do not tamper with the base unit (or charger). Failure to follow these instructions may cause the batteries to swell or explode.
- Avoid the use in the following conditions:
 - High or low extreme temperatures during use, storage or transportation.
 - Replacement of a battery with an incorrect type that can defeat a safeguard.
 - Disposal of a battery into fire or a hot oven, or mechanically crushing or cutting of a battery, that can result in an explosion.
 - Extremely high temperature and/or extremely low air pressure that can result in an explosion or the leakage of flammable liquid or gas.

Installation

Attention:



A nickel metal hydride battery that is recyclable powers the product you have purchased.

Please call 1-800-8-BATTERY (1-800-822-8837) for information on how to recycle this battery.

Important safety instructions

When using your product, basic safety precautions should always be followed to reduce the risk of fire, electric shock, and injury to persons, including the following:

1. Do not use this product near water for example, near a bathtub, washbowl, kitchen sink, or laundry tub, in a wet basement or near a swimming pool.
2. Do not use the telephone to report a gas leak in the vicinity of the leak.
3. Use only the power cord and batteries indicated in this manual. Do not dispose of batteries in a fire. They may explode. Check with local codes for possible special disposal instructions.

SAVE THESE INSTRUCTIONS

Other information

- The applied nameplate is located at the bottom or rear of the product.
- Operating the product near electrical appliances may cause interference. Move away from the electrical appliances.

⚠ CAUTION: Risk of explosion if battery is replaced by an incorrect type. Dispose of used batteries according to the instructions.

Routine care

- **Wipe the outer surface of the product with a soft moist cloth.**
- Do not use benzine, thinner, or any abrasive powder.

Notice for product disposal, transfer, or return

- This product can store your private/confidential information. To protect your privacy/confidentiality, we recommend that you erase information such as phonebook or caller list entries from the memory before you dispose of, transfer, or return the product.

- To dispose of your product, please recycle in accordance with local environmental regulations. For further recycling information please visit <https://shop.panasonic.com/recycle>

Specifications

- **Frequency range:**
1.92 GHz to 1.93 GHz
- **RF transmission power:**
115 mW (max.)
- **Power source:**
120 V AC, 60 Hz
- **Power consumption:**
Standby: 0.2 W
Maximum: 1.2 W
- **Operating conditions:**
0 °C – 40 °C (32 °F – 104 °F), 20 % – 80 % relative air humidity (dry)

Setting up

Connections/Wall mounting

- ① Connect the AC adaptor to the power outlet.
- ② Drive the screws (A) (not supplied) into the wall, if necessary.
B 27.2 mm (1 1/16 inches)

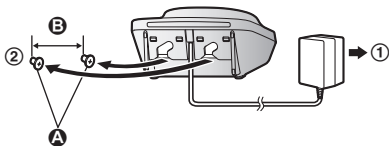

Note:

- The AC adaptor must remain connected at all times. (It is normal for the adaptor to feel warm during use.)
- Make sure that the wall and the fixing method are strong enough to support the weight of the unit.

Battery installation/Battery charging

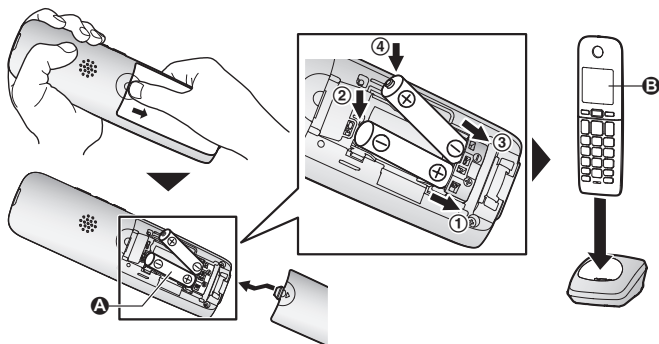

Important:

- Use the supplied rechargeable batteries. For replacement, we recommend using the Panasonic rechargeable batteries noted on page 2.
- USE ONLY rechargeable Ni-MH batteries AAA (R03) size (A).
- Do NOT use alkaline/manganese/Ni-Cd batteries.
- Confirm correct polarities (+, -).

Charge for about 7 hours.

- Confirm “Charging” is displayed (B).
- When the batteries are fully charged, “Fully charged” is displayed.

Note:

- If the batteries are fully charged, but the operating time seems to be shorter, clean the battery ends (+, -) and the charge contacts with a dry cloth and charge again.

Removing the battery

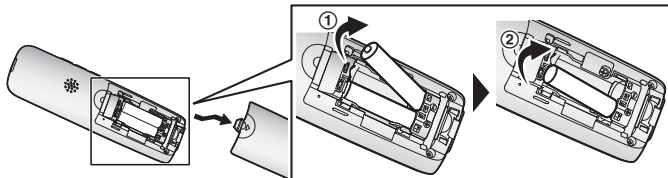

Registering a handset to a base unit

1 Base unit:

Press and hold **[LOCATOR]** for about 5 seconds.

- If all registered handsets start ringing, press **[LOCATOR]** again to stop, then repeat this step.

2 Handset:

Place the handset on the base unit or charger, then wait until a long beep sounds and **Y** is displayed.

Note:

- If an error tone sounds, or if **Y** is displayed, register the handset according to the base unit's operating instructions.

Display language

1 **[MENU]#110**

2 **[↕]**: Select the desired setting. → **[SAVE]** → **[OFF]**

FCC and other information

This equipment is hearing aid compatible as defined by the FCC in 47 CFR Section 68.316.

When you hold the phone to your ear, noise might be heard in your Hearing Aid. Some Hearing Aids are not adequately shielded from external RF (radio frequency) energy. If noise occurs, use an optional headset accessory or the speakerphone option (if applicable) when using this phone. Consult with your audiologist or Hearing Aid manufacturer about the availability of Hearing Aids which provide adequate shielding to RF energy commonly emitted by digital devices.

Installation

WHEN PROGRAMMING EMERGENCY NUMBERS AND(OR) MAKING TEST CALLS TO EMERGENCY NUMBERS:

- 1) Remain on the line and briefly explain to the dispatcher the reason for the call.
- 2) Perform such activities in the off-peak hours, such as early morning or late evenings.

This device complies with Part 15 of the FCC Rules. Operation is subject to the following two conditions:

(1) This device may not cause harmful interference, and (2) this device must accept any interference received, including interference that may cause undesired operation.

Privacy of communications may not be ensured when using this phone.

CAUTION:

Any changes or modifications not expressly approved by the party responsible for compliance could void the user's authority to operate this device.

NOTE:

This equipment has been tested and found to comply with the limits for a Class B digital device, pursuant to Part 15 of the FCC Rules. These limits are designed to provide reasonable protection against harmful interference in a residential installation. This equipment generates, uses, and can radiate radio frequency energy and, if not installed and used in accordance with the instructions, may cause harmful interference to radio communications. However, there is no guarantee that interference will not occur in a particular installation. If this equipment does cause harmful interference to radio or television reception, which can be determined by turning the equipment off and on, the user is encouraged to try to correct the interference by one or more of the following measures:

- Reorient or relocate the receiving antenna.
- Increase the separation between the equipment and receiver.
- Connect the equipment into an outlet on a circuit different from that to which the receiver is connected.
- Consult the dealer or an experienced radio/TV technician for help.

FCC RF Exposure Warning:

- This product complies with FCC radiation exposure limits set forth for an uncontrolled environment.
- This handset may not be collocated or operated in conjunction with any other antenna or transmitter.
- For body-worn operation, the handset must be used only with a non-metallic accessory. Use of other accessories may not ensure compliance with FCC RF exposure requirements.

Notice:

- FCC ID can be found inside the battery compartment or on the bottom of the unit.

Compliance with TIA-1083 standard

Compatible with
Hearing Aid T-Coil



Telephone handsets identified with this logo have reduced noise and interference when used with T-Coil equipped hearing aids and cochlear implants.

Notice:

- This product is designed for use in the United States of America. Sale or use of this product in other countries may violate local laws.
- Cet appareil est conçu pour être utilisé aux États-Unis d'Amérique. La vente ou l'emploi de cet appareil dans certains autres pays peut constituer une infraction à la législation locale.
- Este producto está diseñado para usarse en los Estados Unidos de América. La venta o el empleo de este producto en ciertos países puede constituir violación de la legislación local.
- 本產品專為美國使用而設。若在其他國家銷售或使用，可能會違反當地法例。
- この製品は、日本国外での使用を目的として設計されており、日本国内での使用は法律違反となります。従って、当社では日本国内においては原則として修理などのサービスは致しかねます。

Customer services

Shop Accessories!

for all your Panasonic gear

Go to

<https://shop.panasonic.com/support>

Get everything you need to get the most out of
your Panasonic products

Accessories & Parts for your Camera, Phone, A/V
products, TV, Computers & Networking, Personal
Care, Home Appliances, Headphones, Batteries,
Backup Chargers & more...

Customer Services Directory

For Product Information, Operating Assistance,
Parts, Owner's Manuals, Dealer and Service info
go to <https://shop.panasonic.com/support>

For the hearing or speech impaired TTY: 1- 877-833-8855

As of March 2023

Limited Warranty (ONLY FOR U.S.A.)

Panasonic Products Limited Warranty

Limited Warranty Coverage (For USA Only)

If your product does not work properly because of a defect in materials or workmanship, Panasonic Corporation of North America (referred to as "the warrantor") will, for the length of the period indicated on the chart below, which starts with the date of original purchase ("warranty period"), at its option either (a) repair your product with new or refurbished parts, (b) replace it with a new or a refurbished equivalent value product, or (c) refund your purchase price. The decision to repair, replace or refund will be made by the warrantor.

Product or Part Name	Parts	Labor
Telephone	One (1) Year	One (1) Year

During the "Labor" warranty period there will be no charge for labor. During the "Parts" warranty period, there will be no charge for parts. This Limited Warranty excludes both parts and labor for non-rechargeable batteries, antennas, and cosmetic parts (cabinet). This warranty only applies to products purchased and serviced in the United States. This warranty is extended only to the original purchaser of a new product which was not sold "as is".

Mail-In Service--Online Repair Request

Online Repair Request

To submit a new repair request and for quick repair status visit our Web Site at <https://shop.panasonic.com/support>

When shipping the unit, carefully pack, include all supplied accessories listed in the Owner's Manual, and send it prepaid, adequately insured and packed well in a carton box. When shipping Lithium Ion batteries please visit our Web Site at <https://shop.panasonic.com/support> as Panasonic is committed to providing the most up to date information. Include a letter detailing the complaint, a return address and provide a daytime phone number where you can be reached. A valid registered receipt is required under the Limited Warranty.

IF REPAIR IS NEEDED DURING THE WARRANTY PERIOD, THE PURCHASER WILL BE REQUIRED TO FURNISH A SALES RECEIPT/PROOF OF PURCHASE INDICATING DATE OF PURCHASE, AMOUNT PAID AND PLACE OF PURCHASE. CUSTOMER WILL BE CHARGED FOR THE REPAIR OF ANY UNIT RECEIVED WITHOUT SUCH PROOF OF PURCHASE.

Limited Warranty Limits and Exclusions

This warranty **ONLY COVERS** failures due to defects in materials or workmanship, and **DOES NOT COVER** normal wear and tear or cosmetic damage. The warranty **ALSO DOES NOT COVER** damages which occurred in shipment, or failures which are caused by products not supplied by the warrantor, or failures which result from accidents, misuse, abuse, neglect, mishandling, misapplication, alteration, faulty installation, set-up adjustments, misadjustment of consumer controls, improper maintenance, power line surge, lightning damage, modification, introduction of sand, humidity or liquids, commercial use such as hotel, office, restaurant, or other business or rental use of the product, or service by anyone other than a Factory Service Center or other Authorized Servicer, or damage that is attributable to acts of God.

THERE ARE NO EXPRESS WARRANTIES EXCEPT AS LISTED UNDER "LIMITED WARRANTY COVERAGE".

THE WARRANTOR IS NOT LIABLE FOR INCIDENTAL OR CONSEQUENTIAL DAMAGES RESULTING FROM THE USE OF THIS PRODUCT, OR ARISING OUT OF ANY BREACH OF THIS WARRANTY.

(As examples, this excludes damages for lost time, travel to and from the servicer, loss of or damage to media or images, data or other memory or recorded content. The items listed are not exclusive, but for illustration only.)

ALL EXPRESS AND IMPLIED WARRANTIES, INCLUDING THE WARRANTY OF MERCHANTABILITY, ARE LIMITED TO THE PERIOD OF THE LIMITED WARRANTY.

Some states do not allow the exclusion or limitation of incidental or consequential damages, or limitations on how long an implied warranty lasts, so the exclusions may not apply to you. This warranty gives you specific legal rights and you may also have other rights which vary from state to state. If a problem with this product develops during or after the warranty period, you may contact your dealer or Service Center. If the problem is not handled to your satisfaction, then write to:

Panasonic Corporation of North America
Consumer Affairs Department
Two Riverfront Plaza
Newark NJ 07102-5490

PARTS AND SERVICE, WHICH ARE NOT COVERED BY THIS LIMITED WARRANTY, ARE YOUR RESPONSIBILITY.

Product registration is not mandatory. Failure to complete the form does not affect the consumer's warranty rights.

As of March 2023

IMPORTANT!

If your product is not working properly. . .

- ① **Reconnect AC adaptor to the base unit.**
- ② **Check if telephone line cord is connected.**
- ③ **Use rechargeable Ni-MH batteries.**
(Alkaline/Manganese/Ni-Cd batteries CANNOT be used.)
- ④ Read **troubleshooting** page in the base unit's **Operating Instructions.**



Visit our Web site: <https://shop.panasonic.com/support>

- **FAQ and troubleshooting hints are available.**

Panasonic Corporation of North America

Two Riverfront Plaza, Newark, NJ 07102-5490

© Panasonic Entertainment & Communication Co., Ltd. 2024

For assistance, please visit <https://shop.panasonic.com/support> 15

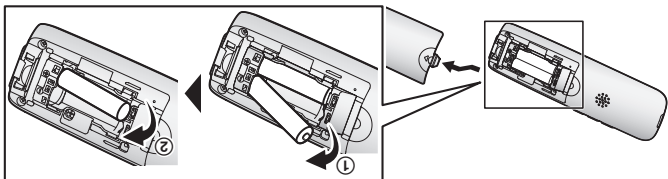

Cómo registrar un auricular a una unidad base

1 Unidad base:

- Si todos los auriculares registrados comienzan a timbrar, oprima **[LOCATOR]** durante aproximadamente 5 segundos. Optima y mantenga oprimido **[LOCATOR]** después aproximadamente 5 segundos.

2 Auricular:

Coloque el auricular en la unidad base o cargador, y después espere hasta que suene un pitido largo y aparezca .

Nota:

- Si suena un tono de error, o si se muestra , registre el auricular de acuerdo con las instrucciones de operación de la unidad base.

Idioma de la pantalla

1 [MENU]#[1][1][0]

2 [↔]: Seleccione la configuración deseada. → [GUARDAR] → [OFF]

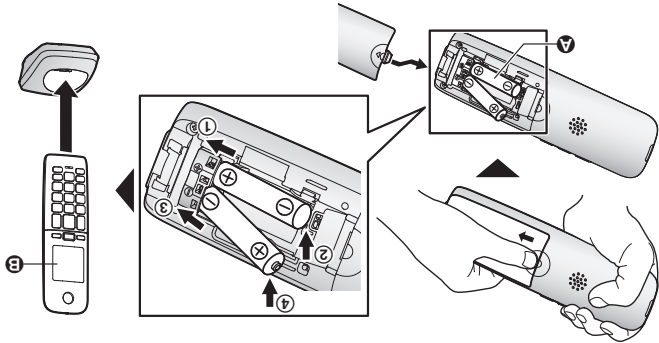

Importante:

- Utilice las baterías recargables que se suministran. Para reemplazarlas, recomendamos el uso de las baterías recargables Panasonic tamaño AAA (R03) (A).
 - NO utilice baterías alcalinas, de manganeso ni de Ni-Cd.
 - Confirme que las polaridades estén correctas (+, -).
 - **Cargue aproximadamente durante 7 horas.**
 - Confirme que se muestre “Cargando” (B).
 - Una vez que las baterías están completamente cargadas, aparece “Carg. comp.”.
- Nota:**
- Si las baterías están completamente cargadas pero el tiempo de funcionamiento parece ser más corto, limpie los extremos de las baterías (+, -) y los contactos de carga con un paño seco y cárguelas de nuevo.

Especificaciones

- Rango de frecuencia: 1.92 GHz a 1.93 GHz
- Potencia de transmisión de RF: 115 mW (máx.)
- Alimentación eléctrica: 120 V CA, 60 Hz
- Consumo de energía: Máximo: 1.2 W
Modo de espera: 0.2 W
- Condiciones de funcionamiento: 0 °C a 40 °C (32 °F a 104 °F), 20% a 80% de humedad relativa (seco)

Instalación





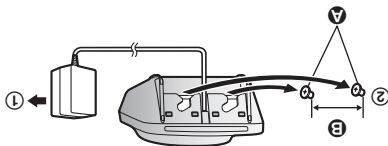







Conexiones/Montaje en la pared

- ① Conecte la clavija del adaptador de corriente a la toma de corriente.
- ② Si lo requiere, inserte los tornillos (A) (no se suministran) en la pared.
- ③ 27.2 mm (1 1/16 pulgadas)



Nota:

- El adaptador de corriente debe permanecer conectado en todo momento (es normal que el adaptador se caliente durante su uso).
- Asegúrese de que la pared y el método de colocación sean lo suficientemente resistentes para soportar el peso de la unidad.

Explicación	Símbolo	Explicación	Símbolo
Equipo de clase II (en el cual la protección contra descarga eléctrica depende del aislamiento doble o del aislamiento reforzado)		Corriente alterna (CA)	
"ENCENDIDO" (alimentación)		Corriente continua (CC)	
"APAGADO" (alimentación)		Tierra de protección	
En reposo (alimentación)		Conexión de puesta a tierra	
"ENCENDIDO"/"APAGADO" (alimentación; interruptor en fase)		Precución, riesgo provocado por radiación visible	
Precución, riesgo de descarga eléctrica		Solo para uso interior	

Símbolos gráficos para utilizar en el equipo y sus descripciones

Información de los accesorios**Accesorios que se suministran**

Accesorio/Pieza número	Cantidad
Cargador/PNLC1098ZB	1
Baterías recargables ¹	2
Cubierta del auricular ² /PNYNTGUA40MR	1

- *1 Lea las instrucciones de operación de la unidad base para obtener información acerca de las baterías de reemplazo.
- *2 La tapa del auricular viene unida a él.

Nota:

- Lea las instrucciones de operación de la unidad base para obtener información sobre accesorios adicionales o de repuesto.

Otra información

- El diseño y especificaciones están sujetos a cambio sin previo aviso.
- Las ilustraciones de estas instrucciones pueden ser ligeramente diferentes al producto.
- En algunas funciones, las operaciones son ligeramente diferentes a las descripciones del manual de instrucciones de la unidad base.
- Es posible que algunas funciones descritas en el manual de instrucciones de las unidades base no estén disponibles.



Gracias por adquirir un producto Panasonic.

Debe registrar este auricular en su unidad base antes de poder usarlo. Este manual de instalación solo describe los pasos necesarios para registrar y comenzar a usar el auricular. Lea las instrucciones de operación de la unidad base para obtener más detalles.

Lea este manual de instalación antes de usar la unidad y guárdelo para consultarlo en el futuro.

Para obtener ayuda, visite nuestro sitio web: <https://shop.panasonic.com/support> para clientes en los EE. UU. (solo en inglés).