

Panasonic[®]

Operating Instructions

Link-to-Cell Cellular Convergence Solution

Model No. **KX-TG7622C**
KX-TG7623C

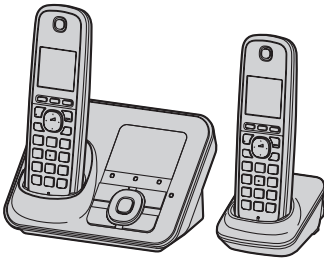

Model shown is KX-TG7622.

DECT
6.0

 **Bluetooth[®]**

Before initial use, see “Getting Started” on page 9.

Thank you for purchasing a Panasonic product.

Please read these operating instructions before using the unit and save them for future reference.

This unit is compatible with Call Display. You must subscribe to the appropriate service offered by your service provider/telephone company. For assistance, please call **1-800-561-5505** or visit us at **www.panasonic.ca**

Table of Contents

Introduction		Turning the answering system on/ off	46
Model composition	3	Greeting message	47
Accessory information	3	Listening to messages using the base unit	47
Important Information		Listening to messages using the handset	48
For your safety	6	Remote operation	49
Important safety instructions	7	Answering system settings	50
For best performance	7	Voice Mail Service for Landline	
Other information	8	Voice Mail service for landline	52
Specifications	8	Intercom/Locator	
Getting Started		Intercom	54
Setting up	9	Handset locator	54
Note when setting up	10	Transferring calls, conference calls	54
Intelligent eco mode	11	Useful Information	
Controls	11	Wall mounting	55
Initial settings	14	Error messages	57
Link to Cell		Troubleshooting	58
Link to cell feature	16	Industry Canada Notices and other information	66
Registering a cellular phone	16	Warranty	67
Link to cell settings	17	Index	
Making/Answering Calls		Index	68
Making cellular calls	21		
Making landline calls	21		
Answering calls	22		
Useful features during a call	23		
Shared Phonebook			
Shared phonebook	26		
Programming			
Programmable settings	29		
Special programming	36		
Registering a unit	38		
Call Display Service			
Using Call Display service	39		
Caller list	41		
Using Bluetooth Devices			
Copying phonebook from a cellular phone (phonebook transfer)	43		
Using a Bluetooth wireless headset (optional) for landline calls	44		
Answering System for Landline			
Answering system for landline	46		

Model composition

Series	Model No.	Base unit	Handset	
		Part No.	Part No.	Quantity
KX-TG7621 series	KX-TG7622	KX-TG7621	KX-TGA410	2
	KX-TG7623	KX-TG7621	KX-TGA410	3

- The suffix (C) in the following model numbers will be omitted in these instructions:
KX-TG7622C/KX-TG7623C

Accessory information

Supplied accessories

No.	Accessory item/Part number	Quantity	
		KX-TG7622	KX-TG7623
①	AC adaptor/PNLV226	2	3
②	Telephone line cord	1	1
③	Rechargeable batteries*1	4	6
④	Handset cover*2	2	3
⑤	Charger	1	2
⑥	Wall mounting adaptor	1	1

*1 See page 4 for replacement battery information.

*2 The handset cover comes attached to the handset.

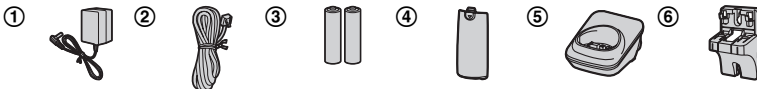

Introduction

Additional/replacement accessories

Please contact your nearest Panasonic dealer for sales information.



Accessory item	Order number
Rechargeable batteries	HHR-4DPA or HHR-4MRA*1
	Battery type: <ul style="list-style-type: none">– Nickel metal hydride (Ni-MH)– 2 x AAA (R03) size for each handset

*1 Replacement batteries may have a different capacity from that of the supplied batteries.

Expanding your phone system

You can expand your phone system by registering optional handsets (6 max.) to a single base unit.



- Optional handsets may be a different color from that of the supplied handsets.

Handset (optional)	
KX-TGA410C	KX-TGA660C
	

Introduction

Bluetooth® devices

You can expand your phone system by registering the following units to a single base unit.

Your Bluetooth cellular phone*1: 2 max. (for cellular calls: page 16)	
Your Bluetooth headset*1: 1 max. (for a wireless hands-free conversation: page 44)	

*1 Your cellular phone and headset must be Bluetooth wireless technology compatible. For more details and the list of compatible cellular phones, please visit our Web site: <http://www.panasonic.ca/link2cell>

Important Information

For your safety

To prevent severe injury and loss of life/property, read this section carefully before using the product to ensure proper and safe operation of your product.

WARNING

Power connection

- Use only the power source marked on the product.
- Do not overload power outlets and extension cords. This can result in the risk of fire or electric shock.
- Completely insert the AC adaptor/power plug into the power outlet. Failure to do so may cause electric shock and/or excessive heat resulting in a fire.
- Regularly remove any dust, etc. from the AC adaptor/power plug by pulling it from the power outlet, then wiping with a dry cloth. Accumulated dust may cause an insulation defect from moisture, etc. resulting in a fire.
- Unplug the product from power outlets if it emits smoke, an abnormal smell, or makes an unusual noise. These conditions can cause fire or electric shock. Confirm that smoke has stopped emitting and contact an authorized service centre.
- Unplug from power outlets and never touch the inside of the product if its casing has been broken open.
- Never touch the plug with wet hands. Danger of electric shock exists.

Installation

- To prevent the risk of fire or electrical shock, do not expose the product to rain or any type of moisture.
- Do not place or use this product near automatically controlled devices such as automatic doors and fire alarms. Radio waves emitted from this product may cause such devices to malfunction resulting in an accident.
- Do not allow the AC adaptor or telephone line cord to be excessively pulled, bent or placed under heavy objects.

Operating safeguards

- Unplug the product from power outlets before cleaning. Do not use liquid or aerosol cleaners.

- Do not disassemble the product.
- Do not spill liquids (detergents, cleansers, etc.) onto the telephone line cord plug, or allow it to become wet at all. This may cause a fire. If the telephone line cord plug becomes wet, immediately pull it from the telephone wall jack, and do not use.

Medical

- Consult the manufacturer of any personal medical devices, such as pacemakers or hearing aids, to determine if they are adequately shielded from external RF (radio frequency) energy. (The product operates in the frequency range of 1.92 GHz to 1.93 GHz, and the RF transmission power is 115 mW (max.))
- Do not use the product in health care facilities if any regulations posted in the area instruct you not to do so. Hospitals or health care facilities may be using equipment that could be sensitive to external RF energy.

CAUTION

Installation and location

- Never install telephone wiring during an electrical storm.
- Never install telephone line jacks in wet locations unless the jack is specifically designed for wet locations.
- Never touch uninsulated telephone wires or terminals unless the telephone line has been disconnected at the network interface.
- Use caution when installing or modifying telephone lines.
- The AC adaptor is used as the main disconnect device. Ensure that the AC outlet is installed near the product and is easily accessible.
- This product is unable to make calls when:
 - the handset batteries need recharging or have failed.
 - there is a power failure.

Battery

- We recommend using the batteries noted on page 4. **USE ONLY rechargeable Ni-MH batteries AAA (R03) size.**
- Do not mix old and new batteries.
- Do not open or mutilate the batteries. Released electrolyte from the batteries is corrosive and may cause burns or injury to the eyes or skin. The electrolyte is toxic and may be harmful if swallowed.

Important Information

- Exercise care when handling the batteries. Do not allow conductive materials such as rings, bracelets, or keys to touch the batteries, otherwise a short circuit may cause the batteries and/or the conductive material to overheat and cause burns.
- Charge the batteries provided with or identified for use with this product only, in accordance with the instructions and limitations specified in this manual.
- Only use a compatible base unit (or charger) to charge the batteries. Do not tamper with the base unit (or charger). Failure to follow these instructions may cause the batteries to swell or explode.

Attention:



A nickel metal hydride battery that is recyclable powers the product you have purchased.

Please call 1-800-8-BATTERY (1-800-822-8837) for information on how to recycle this battery.

Important safety instructions

When using your product, basic safety precautions should always be followed to reduce the risk of fire, electric shock, and injury to persons, including the following:

1. Do not use this product near water for example, near a bathtub, washbowl, kitchen sink, or laundry tub, in a wet basement or near a swimming pool.
2. Avoid using a telephone (other than a cordless type) during an electrical storm. There may be a remote risk of electric shock from lightning.
3. Do not use the telephone to report a gas leak in the vicinity of the leak.
4. Use only the power cord and batteries indicated in this manual. Do not dispose of batteries in a fire. They may explode. Check with local codes for possible special disposal instructions.

SAVE THESE INSTRUCTIONS

For best performance

Base unit location/avoiding noise

The base unit and other compatible Panasonic units use radio waves to communicate with each other.

- For maximum coverage and noise-free communications, place your base unit:
 - at a convenient, high, and central location with no obstructions between the handset and base unit in an indoor environment.
 - away from electronic appliances such as TVs, radios, personal computers, wireless devices, or other phones.
 - facing away from radio frequency transmitters, such as external antennas of mobile phone cell stations. (Avoid putting the base unit on a bay window or near a window.)
- Coverage and voice quality depends on the local environmental conditions.
- If the reception for a base unit location is not satisfactory, move the base unit to another location for better reception.

Environment

- Keep the product away from electrical noise generating devices, such as fluorescent lamps and motors.
- The product should be kept free from excessive smoke, dust, high temperature, and vibration.
- The product should not be exposed to direct sunlight.
- Do not place heavy objects on top of the product.
- When you leave the product unused for a long period of time, unplug the product from the power outlet.
- The product should be kept away from heat sources such as heaters, kitchen stoves, etc. It should not be placed in rooms where the temperature is less than 0 °C (32 °F) or greater than 40 °C (104 °F). Damp basements should also be avoided.
- The maximum calling distance may be shortened when the product is used in the following places: Near obstacles such as hills, tunnels, underground, near metal objects such as wire fences, etc.
- Operating the product near electrical appliances may cause interference. Move away from the electrical appliances.

Important Information

Routine care

- Wipe the outer surface of the product with a soft moist cloth.
- Do not use benzene, thinner, or any abrasive powder.

Other information

CAUTION: Risk of explosion if battery is replaced by an incorrect type. Dispose of used batteries according to the instructions.

Notice for product disposal, transfer, or return

- This product can store your private/confidential information. To protect your privacy/confidentiality, we recommend that you erase information such as phonebook or caller list entries from the memory before you dispose of, transfer, or return the product.

ENERGY STAR

As an ENERGY STAR® Partner, Panasonic has determined that this product meets the ENERGY STAR guidelines for energy efficiency. ENERGY STAR is a U.S. registered mark.



Compliance with TIA-1083 standard

Telephone handsets identified with this logo have reduced noise and interference when used with T-Coil equipped hearing aids and cochlear implants.



Specifications

- **Standard:**
DECT 6.0 (Digital Enhanced Cordless Telecommunications 6.0)
Bluetooth wireless technology 2.0
- **Frequency range:**
1.92 GHz to 1.93 GHz (DECT)
2.402 GHz to 2.48 GHz (Bluetooth)
- **RF transmission power:**
115 mW (max.)
- **Power source:**
120 V AC, 60 Hz
- **Power consumption:**
Base unit:
Standby: Approx. 1.5 W
Maximum: Approx. 4.8 W
Charger:
Standby: Approx. 0.1 W
Maximum: Approx. 2.0 W
- **Operating conditions:**
0 °C – 40 °C (32 °F – 104 °F), 20 % – 80 % relative air humidity (dry)

Note:

- Design and specifications are subject to change without notice.
- The illustrations in these instructions may vary slightly from the actual product.

Setting up

Connections

- Use only the supplied Panasonic AC adaptor PNLV226.
- If you do not connect the telephone line cord and use only cellular lines, set the cellular line only mode to use this unit more conveniently (page 18).

Base unit

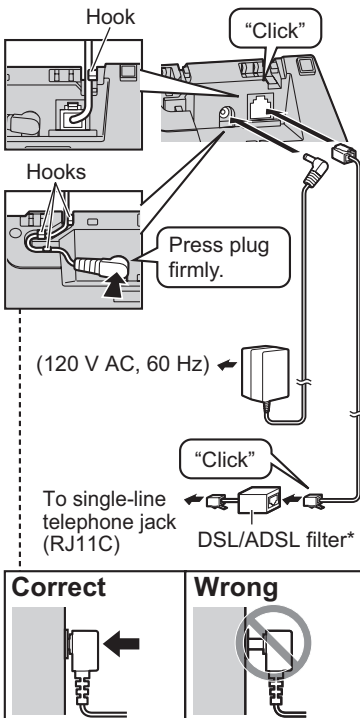

*DSL/ADSL filter (not supplied) is required if you have DSL/ADSL service.

Charger

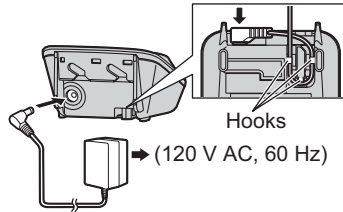

Battery installation

- USE ONLY Ni-MH batteries AAA (R03) size.
- Do NOT use Alkaline/Manganese/Ni-Cd batteries.
- Confirm correct polarities (\oplus , \ominus).

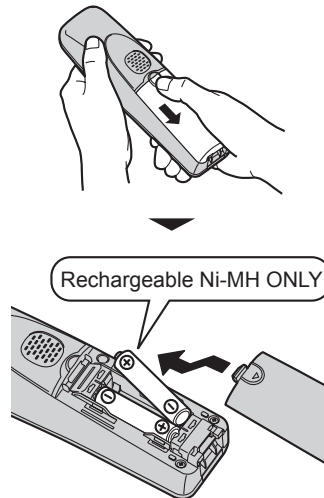

- When the language selection is displayed, see page 14.

Getting Started

Battery charging

Charge for about 7 hours.

- When the batteries are fully charged, the charge indicator goes off and "Fully charged" is displayed.

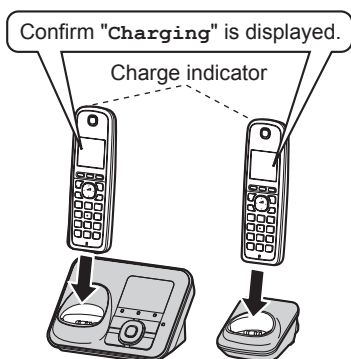

Note when setting up

Note for connections

- The AC adaptor must remain connected at all times. (It is normal for the adaptor to feel warm during use.)
- The AC adaptor should be connected to a vertically oriented or floor-mounted AC outlet. Do not connect the AC adaptor to a ceiling-mounted AC outlet, as the weight of the adaptor may cause it to become disconnected.

During a power failure

We recommend connecting a corded-type telephone (without AC adaptor) to the same telephone line or to the same telephone line jack using a Panasonic T-adaptor.

Note for battery installation

- Use the supplied rechargeable batteries. For replacement, we recommend using the Panasonic rechargeable batteries noted on page 4, 6.
- Wipe the battery ends (+, -) with a dry cloth.
- Avoid touching the battery ends (+, -) or the unit contacts.

Note for battery charging

- It is normal for the handset to feel warm during charging.
- Clean the charge contacts of the handset, base unit, and charger with a soft and dry cloth once a month. Clean more often if the unit is exposed to grease, dust, or high humidity.

Battery level

Icon	Battery level
	High
	Medium
	Low
	Needs charging.
	Empty

Panasonic Ni-MH battery performance (supplied batteries)

Operation	Operating time
In continuous use	13 hours max.*1
Not in use (standby)	11 days max.*1

*1 If Eco mode is on.

Note:

- Actual battery performance depends on usage and ambient environment.

- Even after the batteries are fully charged, the handset can be left on the base unit or charger without any ill effect on the batteries.
- The battery level may not be displayed correctly after you replace the batteries. In this case, place the handset on the base unit or charger and let it charge for at least 7 hours.

Intelligent eco mode

This feature automatically reduces handset power consumption by suppressing handset transmission power when the handset is close to the base unit.

- When this feature is activated, **ECO** is displayed. However, during a cellular call, **ECO** is not displayed even though this feature is activated.
- Eco mode is turned off when the clarity booster is activated (page 24).

Controls

Base unit

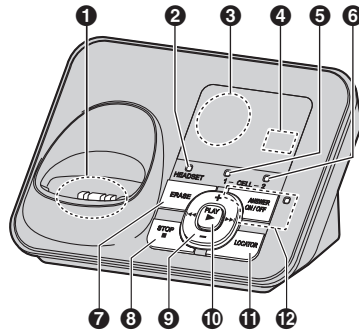

- 1 Charge contacts
- 2 HEADSET indicator
- 3 Speaker
- 4 Message counter
- 5 CELL 1 indicator
- 6 CELL 2 indicator
- 7 [ERASE]
- 8 [■] (STOP)
- 9 [+]/[-] (Volume up/down)
[◀]/[▶] (Repeat/Skip)
- 10 [▶] (PLAY)
Message indicator
- 11 [LOCATOR]
- 12 [ANSWER ON/OFF]
ANSWER ON/OFF indicator

Getting Started

Handset

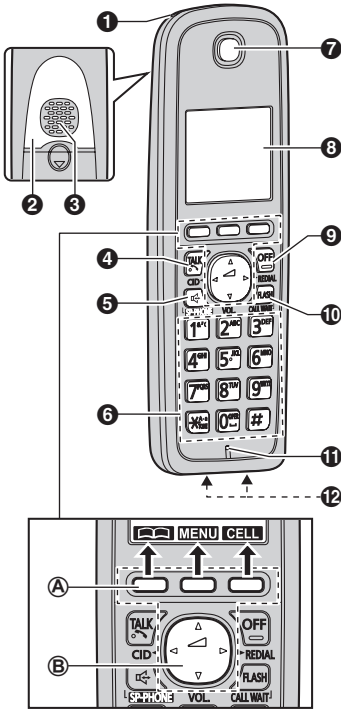

- ① Charge indicator
Ringer indicator
Message indicator
- ② Nonslip pad
 - Nonslip pad offers support when you cradle the handset between your shoulder and ear.
- ③ Speaker
- ④ **[TALK]**
- ⑤ **[SP-PHONE: Speakerphone]**
- ⑥ Dial keypad (**[TONE]**)
- ⑦ Receiver
- ⑧ Display
- ⑨ **[OFF]**
- ⑩ **[FLASH] [CALL WAIT]**

- ⑪ Microphone
- ⑫ Charge contacts

Control type

Ⓐ Soft keys

The handset features 3 soft keys. By pressing a soft key, you can select the feature shown directly above it on the display.













Ⓑ Navigator key

- **[▲], [▼], [◀], or [▶]**: Scroll through various lists and items.
- **◀ VOL. (Volume: [▲] or [▼])**: Adjust the receiver or speaker volume while talking.
- **[◀] CID (Call Display)**: View the caller list.
- **[▶] REDIAL**: View the redial list.

Display/Indicators

Handset display items

Item	Meaning
	Within base unit range
	Out of base unit range
	The landline is in use. <ul style="list-style-type: none"> • When flashing: The call is put on hold. • When flashing rapidly: An incoming call is now being received.
	A cellular line is in use. <ul style="list-style-type: none"> • When flashing: The cellular call is put on hold. • When flashing rapidly: A cellular call is being received.

Item	Meaning
	A cellular phone is connected.*1 Ready to make/receive cellular calls. <ul style="list-style-type: none"> When turned off: A cellular phone is not connected to the base unit (page 18).
	<ul style="list-style-type: none"> The cellular line is selected for the ringer setting. A cellular call is being received on that line.
	Eco mode is on.*2 (page 11)
	Equalizer is set. (page 24)
	Speakerphone is on. (page 21)
	Ringer volume is off.*3 (page 31, 33)
	Night mode is on. (page 36)
	Privacy mode is on. (page 34)
	Alarm is on. (page 36)
	Handset number
	Battery level
	Blocked call (page 37)
	Clarity booster is on.*2 (page 24)
In use	Answering system is being used by another handset or the base unit.
Cell1 in use	Someone is using the cellular line.
Cell2 in use	
Line in use	Someone is using the landline.

- *1 Corresponding cellular line(s) is indicated next to the item.
- *2 During a cellular call, the item is not displayed even though the feature is activated.
- *3 Corresponding lines (1, 2: cellular line, L: landline) are indicated next to the item. If all lines are turned off, no line is indicated.

Base unit display item

Item	Meaning
	Answering system answers calls with a greeting message and caller messages are not recorded. ("Selecting Greeting only ", page 51)

CELL 1/CELL 2 indicators on the base unit

The CELL 1/CELL 2 indicators show each cellular line status.

Status	Meaning
Green (On)	A cellular phone is connected. Ready to make/receive cellular calls.
Green (Flashing)	<ul style="list-style-type: none"> The cellular line is in use. Phonebook entries are being copied from a cellular phone (page 43).
Green (Flashing rapidly)	A cellular call is being received.
Amber (On)	A cellular phone is not connected to the base unit (page 18).
Amber (Flashing rapidly)	The base unit is searching for the registered cellular phone.

Getting Started

Status	Meaning
Red (Flashing)	<ul style="list-style-type: none">– The base unit is registering a cellular phone.– A cellular call is put on hold.
Light off	A cellular phone is not registered to the base unit.

HEADSET indicator on the base unit

The HEADSET indicator shows the Bluetooth headset status.

Status	Meaning
Green (On)	A Bluetooth headset is connected to the base unit. Ready to use it.
Green (Flashing)	A Bluetooth headset is in use.
Green (Flashing rapidly)	A landline call is being received.
Amber (On)	The Bluetooth headset is not connected to the base unit.
Amber (Flashing rapidly)	The base unit is searching for the registered Bluetooth headset.
Red (Flashing)	The base unit is registering a headset.
Light off	A Bluetooth headset is not registered to the base unit.



Initial settings

■ Direct command code:

Programmable settings can be accessed by pressing **[MENU]**, **[#]** and then the corresponding code on the dial keypad (page 29).

Example: Press **[MENU]#[1][0][1]**.

■ Symbol meaning:

Symbol	Meaning
	Perform with the handset.
	Perform with the base unit.
Example: [↕]: "OFF"	Press [▼] or [▲] to select the words in quotations.

Important:

- When you install the batteries for the first time, the handset may prompt you to set display language and date and time.
 - ① Perform step 2 in "Display language", page 14, and then press **[SELECT]**.
 - ② Continue from step 2 in "Date and time", page 15.

Display language

You can select either "English" or "Français" as the display language. The default setting is "English".

- 1 **[MENU]#[1][1][0]**
- 2 **[↕]**: Select the desired setting. → **[SAVE]**
- 3 **[OFF]**

Date and time

- 1 **[MENU]** **#** **1** **0** **1**
- 2 Enter the current month, date, and year by selecting 2 digits for each.
Example: July 15, 2011
0 **7** **1** **5** **1** **1**
- 3 **[OK]**
- 4 Enter the current hour and minute (12-hour clock format) by selecting 2 digits for each.
Example: 9:30
0 **9** **3** **0**
- 5 **[AM/PM]**: Select **"AM"** or **"PM"**.
- 6 **[SAVE]** → **[OFF]**

Note:

- When English is selected as the display language, 12-hour clock format is used. When French is selected, 24-hour clock format is used.
- The date and time may be incorrect after a power failure. In this case, set the date and time again.

Voice guidance language

You can select either **"English"** or **"Français"** as the voice guidance language of the answering system. The default setting is **"English"**.

- 1 **[MENU]** **#** **1** **1** **2**
- 2 **[↓]**: Select the desired setting. →
[SAVE]
- 3 **[OFF]**

Dialing mode

If you cannot make calls, change this setting according to your telephone line service. The default setting is **"Tone"**.

"Tone": For tone dial service.

"Pulse": For rotary/pulse dial service.

- 1 **[MENU]** **#** **1** **2** **0**
- 2 **[↓]**: Select the desired setting.

- 3 **[SAVE]** → **[OFF]**

Link to Cell

Link to cell feature

To use this feature, you must first register and connect your cellular phones to the base unit (page 16). Your cellular phones must be Bluetooth wireless technology compatible with this product.

This feature allows you to:

- make or answer cellular calls using your home phone (handset or base unit) with better reception.
- maximize the benefits of cellular services (such as free night and weekend calls, or cellular to cellular call plans) by utilizing unused peak minutes with your home phone.
- conserve the battery power of your cellular phone while the unit is on a cellular call. (We recommend charging your cellular phone during the cellular call as your cellular phone battery is being consumed.)

Important:

- Up to 2 cellular phones can be registered. However, only one Bluetooth device (cellular phone or headset) can be connected to the base unit at a time.
- Locate your cellular phone near the base unit. If the cellular phone is too close to the base unit during a cellular call, you may hear noise. For best performance, we recommend placing the cellular phone between 0.6 m to 3 m (2 feet to 10 feet) away from the base unit.

Trademarks

- The Bluetooth® word mark and logos are owned by the Bluetooth SIG, Inc. and any use of such marks by Panasonic Corporation is under license. All other trademarks identified herein are the property of their respective owners.

Registering a cellular phone

Important:

- For more details and the list of compatible cellular phones, please visit our Web site:
<http://www.panasonic.ca/link2cell>
- Before registering a Bluetooth enabled cellular phone to the base unit:
 - we recommend you change the PIN (page 19).
 - make sure that no Bluetooth device such as a Bluetooth headset is connected to your cellular phone.

1 Handset:

[MENU]

For CELL 1: #6241

For CELL 2: #6242

- After the CELL 1 or CELL 2 indicator on the base unit starts flashing red, the rest of the procedure must be completed within 5 minutes.

2 Your cellular phone:

While the CELL 1 or CELL 2 indicator is flashing red, follow the instructions of your cellular phone to enter the registration mode.

- Depending on your cellular phone, it may ask you to enter the base unit PIN (default: "0000").

3 Handset:

Wait until a long beep sounds.

- It may take more than 10 seconds to complete registration.
- When the CELL 1 or CELL 2 indicator lights green, the cellular phone is connected to the base unit. You are ready to make cellular calls.

4 To select which unit receives calls for the cellular line, press [OK] then continue from step 3, "Selecting

which unit receives cellular calls”, page 17.

- If not required, go to step 5.

5 [OFF]

Note:

- Make sure that your cellular phone is set to connect to this product automatically. Refer to your cellular phone’s operating instructions.
- Make sure you cancel your cellular phone’s current registration if you want to register it to the other line (page 20).

Link to cell settings

Selecting which unit receives cellular calls

You can select which unit rings and receives calls for a cellular line. When “**All**” is selected, all handsets and the base unit ring.

- 1 [MENU]**
- 2** For CELL 1: **#6271**
For CELL 2: **#6272**
- 3 [↕]**: Select the desired handset or “**All**”.
- 4 [SAVE] → [OFF]**

Note:

- When you select a specific handset to receive calls for a cellular line, other handsets cannot answer the calls.
- When you change the setting to “**All**”, the base unit ringer volume also returns to the lowest level even if the ringer volume has been changed.

Ring as cell mode

Once this feature is turned on, the handset and base unit ring using the same ringer tone as your cellular phone.

The following settings are available:

- “**OFF**”: Turn this feature off to use the ringer tones of the handset and base unit. Caller information is announced depending on the Talking Call Display setting (page 33).
- “**On (with Talking CID)**” (default): The handset and base unit use your cellular phone’s ringer tone. Caller information is announced even if the Talking Call Display is turned off.
- “**On (without Talking CID)**”: The handset and base unit use your cellular phone’s ringer tone. Caller information is not announced even if the Talking Call Display is turned on.

Important:

- To use this feature, your cellular phone must support Bluetooth in-band ringtone. Refer to your cellular phone’s operating instructions.

- 1 [MENU]**
- 2** For CELL 1: **#6141**
For CELL 2: **#6142**
- 3 [↕]**: Select the desired setting.
- 4 [SAVE] → [OFF]**

Note:

- The units use the preset ringer tones (page 33) instead of your cellular phone’s ringer tone when a cellular call is being received if:
 - your cellular phone is in night mode (depending on your cellular phone).
 - the base unit is in use.
 - 2 handsets are sharing a landline call.
- If your cellular phone is in night mode with “**On (with Talking CID)**” set, the unit announces caller information even when Talking Call Display is turned off (page 33).

Link to Cell

To use the handset ringer tone instead of your cellular phone's ringer tone

Select "OFF" in step 3, "Ring as cell mode", page 17.

To change the handset ringer tone for a cellular line, see page 31.

Auto connection to the cellular phone

After registration, your cellular phone is connected to the base unit. If you move the cellular phone out of base unit range, the cellular phone is disconnected from the base unit. This feature allows the base unit to try to reconnect the cellular phone at regular intervals when it returns within base unit range. You can set the interval. The default setting is "1 min".

Important:

- When you are using a cellular line or a Bluetooth headset, the base unit loses its connection from other Bluetooth devices (cellular phone or headset). To automatically resume the connection to cellular phones, leave the auto connection on.
- Some cellular phones lose connection after usage, please check the specification of your cellular phone for more details.

1 [MENU]#632

2 [↕]: Select the desired setting.

3 [SAVE] → [OFF]

Note:

- Some cellular phone may ask you if you accept the connection requirement from the base unit. In that case, select "OFF" in step 2. Check the specification of your cellular phone.

Connecting/disconnecting the cellular phone manually

When you make or answer calls with your cellular phone, we recommend disconnecting it from the base unit, otherwise received audio may not be heard on your cellular phone.

You can also manually reconnect the cellular phone to the base unit without waiting for the auto connection feature to resume the connection.

1 [MENU]

2 To connect/disconnect:

For CELL 1: #6251

For CELL 2: #6252

- A long beep sounds.

3 [OFF]

Cellular line only mode (If you do not use the landline)

If you do not use the landline, we recommend setting the unit to the cellular line only mode.

1 [MENU]#157

2 To turn on:

[↕]: "On" → [SELECT] →

[↕]: "Yes" → [SELECT]

To turn off:

[↕]: "OFF" → [SELECT]

Note:

- Once you set this mode, you can use [📶] or [📶] instead of [CELL] (page 21).
- Once you set this mode, the following features cannot be used:
 - Landline features (page 34)
 - Answering system (page 46)
 - Voice Mail features (page 52)
- After this mode is turned on or off, the base unit reboots.
 - Bluetooth connections from cellular phones or headset are disconnected. If the auto

connection is turned on (page 18), the cellular phones are reconnected.

- Ψ will be displayed on the handset momentarily. The handset can be used once Ψ is displayed.

When you use the landline again

Before connecting the telephone line to the base unit, select “**off**” in step 2, “Cellular line only mode (If you do not use the landline)”, page 18.

Cellular line selection

This feature determines which cellular line is selected to make cellular calls when:

- you press **[CELL]** on the handset.
- you press **[↶]** or **[↷]** on the handset while the cellular line only mode is turned on.

The following settings are available:

- “**Manual**” (default): You can select the desired cellular line when making a call.
- “Cellular phone 1”: CELL 1 is selected.
- “Cellular phone 2”: CELL 2 is selected.

- 1 **[MENU]****#[6][3][4]**
- 2 **[↕]**: Select the desired setting.
- 3 **[SAVE]** → **[OFF]**

Storing your area code (for dialing only a 7-digit phone number to make a local call)

You need to add your area code when making cellular calls to a phone number in your area. Once you store your area code, it is automatically added to the beginning of the 7-digit phone number when making cellular calls.

- 1 **[MENU]****#[6][3][3]**
- 2 Enter the 3-digit area code.
 - To correct a digit, press **[CLEAR]**.
- 3 **[SAVE]** → **[OFF]**

Changing the Bluetooth PIN (Personal Identification Number)

The PIN is used to register cellular phones to the base unit. The default PIN is “0000”. To prevent unauthorized access to this product, we recommend that you change the PIN, and keep it confidential.

Important:

- Please make note of your new PIN. The unit does not reveal the PIN to you. If you forget your PIN, see page 65.

- 1 **[MENU]****#[6][1][9]**
- 2 Enter the new 4-digit PIN. → **[OK]**
- 3 Enter the new 4-digit PIN again. → **[SAVE]**
- 4 **[OFF]**



Changing the PIN for the second time

Follow step 1, “Changing the Bluetooth PIN (Personal Identification Number)”, page 19. Enter the current 4-digit PIN, then continue from step 2.

Link to Cell

Deregistering Bluetooth devices

A handset can cancel a registration of another Bluetooth devices (cellular phone or headset) that is stored to the base unit.

- 1 **[MENU]** **#** **1** **3** **4**
- 2 **[↓]**: Select the desired device. →
[SELECT]
 -  indicates a cellular phone, and
 -  indicates a headset.
- 3 **[↓]**: “Yes” → **[SELECT]**
 - When the cellular phone is deregistered, the CELL 1 or CELL 2 indicator is turned off.
 - When the headset is deregistered, the HEADSET indicator is turned off.
- 4 **[OFF]**

Making cellular calls

Important:

- Only 1 cellular line can be used at a time.
- Before making calls, confirm that the CELL 1 or CELL 2 indicator lights green (page 13).

- 1 Lift the handset and dial the phone number.
 - To correct a digit, press **[CLEAR]**.
- 2 **[CELL]**
 - The unit starts dialing when:
 - only 1 cellular phone is registered.
 - a specific line is set to make cellular calls (page 19).Go to step 4.
- 3 **[↕]**: Select the desired cellular phone. → **[SELECT]**
- 4 When you finish talking, press **[OFF]** or place the handset on the base unit or charger.

Note:

- To switch to the speaker, press **[☎]**. To switch back to the receiver, press **[☎]/[↶]**.

Adjusting the receiver or speaker volume

Press **[▲]** or **[▼]** repeatedly while talking.

Making a cellular call using the redial list

The last 5 phone numbers dialed are stored in the redial list (each 48 digits max.).

- 1 **[▶]** REDIAL
- 2 **[↕]**: Select the desired phone number.
- 3 **[CELL]**
 - The unit starts dialing when:

- only 1 cellular phone is registered.
- a specific line is set to make cellular calls (page 19).

- 4 **[↕]**: Select the desired cellular phone. → **[SELECT]**

Erasing a number in the redial list

- 1 **[▶]** REDIAL
- 2 **[↕]**: Select the desired phone number. → **[ERASE]**
- 3 **[↕]**: “Yes” → **[SELECT]**
- 4 **[OFF]**

Making landline calls

- 1 Lift the handset and dial the phone number.
 - To correct a digit, press **[CLEAR]**.
- 2 **[↶]**
- 3 When you finish talking, press **[OFF]** or place the handset on the base unit or charger.

Using the speakerphone

- 1 Dial the phone number and press **[☎]**.
 - Speak alternately with the other party.
- 2 When you finish talking, press **[OFF]**.

Note:

- For best performance, use the speakerphone in a quiet environment.
- To switch back to the receiver, press **[☎]/[↶]**.

Making a call using the redial list

- 1 **[▶]** REDIAL
- 2 **[↕]**: Select the desired phone number.
- 3 **[↶]**

Making/Answering Calls

Pause (for PBX/long distance service users)

A pause is sometimes required when making calls using a PBX or long distance service. When storing a calling card access number and/or PIN in the phonebook, a pause is also needed (page 28).

Example: If you need to dial the line access number "9" when making outside calls with a PBX:

- 1 **9** → **[PAUSE]**
- 2 Dial the phone number. → **[↶]**

Note:

- A 3.5 second pause is inserted each time **[PAUSE]** is pressed. Repeat as needed to create longer pauses.

Answering calls

When a call is being received, the ringer indicator flashes rapidly.

- 1 Lift the handset and press **[↶]** or **[☎]** when the unit rings.
 - To answer a cellular call, you can also press **[CELL]**.
 - You can also answer the call by pressing any dial key from **0** to **9**, **[*]**, or **[#]**. (**Any key answer feature**)
- 2 When you finish talking, press **[OFF]** or place the handset on the base unit or charger.

Auto talk

You can answer calls simply by lifting the handset off the base unit or charger. You do not need to press **[↶]**. To turn this feature on, see page 34.

Adjusting the handset ringer volume

■ While the handset is ringing for an incoming call:

Press **[▲]** or **[▼]** repeatedly to select the desired volume.

■ Programming the volume beforehand:

1 To change the cellular line ringer volume:

For CELL 1:

[MENU]# [6] [2] [8] [1]

For CELL 2:

[MENU]# [6] [2] [8] [2]

To change the landline ringer volume:

[MENU]# [1] [6] [0]

- 2 **[↕]**: Select the desired volume.
- 3 **[SAVE]** → **[OFF]**

Temporary handset ringer off

While the handset is ringing for a call, you can turn the ringer off temporarily by pressing **[⏏]**.

Adjusting the base unit ringer volume

■ While the base unit is ringing for an incoming call:

Press **[+]** or **[-]** repeatedly to select the desired volume.

- To turn the ringer off, press and hold **[-]** until the unit beeps.

■ Programming the volume beforehand:

1 To change the cellular line ringer volume:

For CELL 1:

[MENU]# [*] [6] [2] [8] [1]

For CELL 2:

[MENU]# [*] [6] [2] [8] [2]

To change the landline ringer volume:

[MENU]# [*] [1] [6] [0]

- 2 [↕]: Select the desired volume.
- 3 [SAVE] → [OFF]

Useful features during a call

Hold

This feature allows you to put an outside call on hold.

- 1 Press [MENU] during an outside call.
 - 2 [↕]: “Hold” → [SELECT]
 - 3 To release hold on the cellular line:
Press [CELL].
 - Another handset user can take the call: [CELL]*1 → [SELECT]
- *1 The call is taken when:
- only 1 cellular phone is registered.
 - the line is set to make cellular calls (page 19).

To release hold on the landline:
Press [↵].

- Another handset user can take the call by pressing [↵].

Note:

- If a call is kept on hold for more than 9 minutes, an alarm tone starts to sound and the ringer indicator flashes rapidly. After 1 additional minute on hold, the call is disconnected.
- If another phone is connected to the same line, you can also take the call by lifting its handset.

Mute

While mute is turned on, you can hear the other party, but the other party cannot hear you.

- 1 Press [MUTE] during conversation.
 - [MUTE] flashes.
- 2 To return to the conversation, press [MUTE] again.

Note:

- [MUTE] is a soft key visible on the handset display during a call.

Flash for landline calls

[FLASH] allows you to use the special features of your host PBX such as transferring an extension call, or accessing optional telephone services.

Note:

- To change the flash time, see page 34.

For Call Waiting or Visual Call Waiting service users

To use Call Waiting or Visual Call Waiting, you must first subscribe with your service provider/telephone company.

This feature allows you to receive calls while you are already talking on the phone. If you receive a call while on the phone, you will hear a Call Waiting tone. **If you subscribe to both Call Display and Visual Call Waiting services**, the 2nd caller's information is displayed after you hear the Call Waiting tone on the handset.

- 1 Press [CALL WAIT] to answer the 2nd call.
- 2 To switch between calls, press [CALL WAIT].

Note:

- Please contact your service provider/telephone company for details and availability of this service in your area.

Making/Answering Calls

Temporary tone dialing for landline calls (for rotary/pulse service users)

You can temporarily switch the dialing mode to tone when you need to access touch-tone services (for example, answering services, telephone banking services, etc.).

Press **[*]** (TONE) before entering access numbers which require tone dialing.

Handset clarity booster

This feature can improve sound clarity when the handset is used in an area where there may be interference. During an outside call, this feature is turned on automatically when necessary.

- When this feature is turned on, **[BOOST]** is displayed. However, during a cellular call, **[BOOST]** is not displayed even though the feature is activated.

Handset equalizer

This feature clarifies the voice of the person you are talking to, producing a more natural-sounding voice that is easier to hear and understand.

- 1 Press **[MENU]** while talking.
- 2 **[↕]**: “Equalizer” → **[SELECT]**
- 3 **[↕]**: Select the desired setting.
- 4 Press **[OK]** to exit.

Note:

- When this feature is activated, **[EQ]** is displayed while talking.
- Depending on the condition and quality of your telephone line, this feature may emphasize existing line noise. If it becomes difficult to hear, turn this feature off.
- This feature is not available while using the speakerphone.

Call share

You can join an existing outside call.

Important:

- When the privacy mode is on, you cannot join the conversation. Turn it off.

■ While another unit is on a cellular call:

- 1 To join the conversation, press **[CELL]**.
 - You can join the conversation when:
 - only 1 cellular phone is registered.
 - the line is set to make cellular calls (page 19).
- 2 **[↕]**: Select the desired cellular phone. → **[SELECT]**

■ While another unit is on a landline call:

To join the conversation, press **[↶]**.

Note:

- A maximum of 3 parties (including 1 outside party) can join a conversation using 2 extensions. (**3-way conference**)

Privacy mode

When the privacy mode is “on”, the unit prevents other users from joining your conversations with outside callers. To allow other users to join your conversations (call share), leave this feature off. The default setting is “off”.

- 1 **[MENU]** **[#]** **[1]** **[9]** **[4]**
- 2 **[↕]**: Select “on” or “off”.
- 3 **[SAVE]** → **[OFF]**
 - When the privacy mode is turned on, **[PRIV]** is displayed during an outside call.

Making/Answering Calls

Transferring a cellular call between the handset and a cellular phone

Transferring a cellular call from the handset to a cellular phone

- 1 Press **[MENU]** during a cellular call.
- 2 **[↕]**: "Transfer to cell" → **[SELECT]**
 - The cellular call is transferred to the cellular phone.

Note:

- Depending on your cellular phone type, you may need to set the cellular phone ready to talk before transferring. For example, if your cellular phone has a top cover, open it beforehand.

Transferring a cellular call from a cellular phone to the handset

During a conversation using a cellular phone, the call cannot be transferred to the handset by the cellular phone. Perform the following with the handset.

- 1 During a conversation using a cellular phone, press **[CELL]**.
 - The call is transferred to the handset when:
 - only 1 cellular phone is registered.
 - the line is set to make cellular calls (page 19).
- 2 **[↕]**: Select the desired cellular phone. → **[SELECT]**
 - The call is transferred to the handset.

Using the other line during a conversation

You can handle a cellular call and a landline call at the same time. When another call is being received during a

conversation, the interrupt tone sounds (page 33), and the 2nd caller's information is displayed if you subscribe to Call Display (page 39). You can answer the 2nd call while holding the 1st call.

Making/answering a cellular call during a conversation on the landline

- 1 Press **[MENU]** during a landline call.
- 2 **[↕]**: "Hold" → **[SELECT]**
- 3 **To make a 2nd call:**
Dial the phone number. → **[CELL]***1 → **[↕]**: Select the desired cellular phone. → **[SELECT]**
 - *1 The unit starts dialing when:
 - only 1 cellular phone is registered.
 - a specific line is set to make cellular calls (page 19).

To answer a 2nd call:

[CELL]

- To hold the 2nd call: **[MENU]** → **[↕]**: "Hold" → **[SELECT]**

- 4 To hang up the 2nd call and return to the 1st call (landline call), press **[OFF]**, then press **[↶]**.

Making/answering a landline call during a conversation on a cellular line

- 1 Press **[MENU]** during a cellular call.
- 2 **[↕]**: "Hold" → **[SELECT]**
- 3 **To make a 2nd call:**
Dial the phone number. → **[↶]**
To answer a 2nd call:
[↶]
 - To hold the 2nd call: **[MENU]** → **[↕]**: "Hold" → **[SELECT]**
- 4 To hang up the 2nd call and return to the 1st call (cellular call), press **[OFF]**, then press **[CELL]**.

Shared Phonebook

Shared phonebook

The shared phonebook allows you to make calls without having to dial manually. Any handset registered to the base unit can use the shared phonebook. You can add 3050 names and phone numbers to the shared phonebook, and assign each phonebook entry to the desired group ("Home", "Cell 1", "Cell 2").

Important:

- Only 1 person can access the shared phonebook at a time.
- Call Display subscribers can use group ringer tone features (page 40).
- You can copy phonebook entries from a Bluetooth cellular phone to the unit's shared phonebook (page 43).

Adding entries

- 1 **[📖] → [ADD]**
- 2 Enter the party's name (16 characters max.). → **[OK]**
- 3 Enter the party's phone number (24 digits max.). → **[OK]**
- 4 **[↕]**: Select the desired group. → **[SELECT]** 2 times
 - To add other entries, repeat from step 2.
- 5 **[OFF]**

Character table for entering names

While entering characters, you can switch between uppercase and lowercase by pressing **[↔]** (A→a).

Key	Character
[1]	& ' () * , - . / 1
[2]	A B C 2
	a b c 2

Key	Character
[3]	D E F 3
	d e f 3
[4]	G H I 4
	g h i 4
[5]	J K L 5
	j k l 5
[6]	M N O 6
	m n o 6
[7]	P Q R S 7
	p q r s 7
[8]	T U V 8
	t u v 8
[9]	W X Y Z 9
	w x y z 9
[0]	_ 0
[#]	#

- To enter another character that is located on the same dial key, first press **[▶]** to move the cursor to the next space.
- If you do not press any dial key within 5 seconds after entering a character, the character is fixed and the cursor moves to the next space.
- _ in the above table represents a single space.

Erasing the character or number

Press **[◀]** or **[▶]**. → **[CLEAR]**

- Press and hold **[CLEAR]** to erase all characters or numbers.



Groups

Groups can help you find entries in the phonebook quickly and easily. When adding an entry to the phonebook, you can assign it to one of 3 groups. You can search for phonebook entries by group. The group ringer tone feature is available for Call Display subscribers (page 40).



Finding and calling from a phonebook entry

Scrolling through all entries

■ Using a cellular line

- 1 
- 2 : Select the desired entry.
- 3 **[CELL]**
 - The unit starts dialing when:
 - only 1 cellular phone is registered.
 - a specific line is set to make cellular calls (page 19).
- 4 : Select the desired cellular phone. → **[SELECT]**

■ Using the landline

- 1 
- 2 : Select the desired entry.
- 3 



Searching by first character

- 1 
- 2 Press the dial key (**[0]** – **[9]** or **[#]**) which contains the character you are searching for (page 26).
 - Press the same dial key repeatedly to display the first entry corresponding to each character located on that dial key.
 - If there is no entry corresponding to the character you selected, the next entry is displayed.



- 3 : Scroll through the phonebook if necessary.
- 4 To make a cellular/landline call, continue from step 3, "Scrolling through all entries", page 27.

Searching by query

You can narrow down the search to enter the first characters of a name.

- 1  → 
- 2 To search for the name, enter the first characters (up to 4) in uppercase (page 26).
 - Characters cannot be entered in lowercase.
 - If there is no entry corresponding to the characters you selected, the next entry is displayed.
- 3 **[OK]**
- 4 : Scroll through the phonebook if necessary.
- 5 To make a cellular/landline call, continue from step 3, "Scrolling through all entries", page 27.

Searching by group

- 1  → **[GROUP]**
- 2 : Select the group you want to search. → **[SELECT]**
 - If you select "A11", the unit ends the group search.
- 3 : Select the desired entry.
- 4 To make a cellular/landline call, continue from step 3, "Scrolling through all entries", page 27.

Editing entries

- 1 Find the desired entry (page 27). → **[MENU]**
- 2 : "Edit" → **[SELECT]**
- 3 Edit the name if necessary (16 characters max.; page 26). → **[OK]**

Shared Phonebook

- 4 Edit the phone number if necessary (24 digits max.). → **[OK]**
- 5 **[↕]**: Select the desired group (page 27). → **[SELECT]** 2 times
- 6 **[OFF]**

Erasing entries

Erasing an entry

- 1 Find the desired entry (page 27). → **[ERASE]**
- 2 **[↕]**: “Yes” → **[SELECT]**
- 3 **[OFF]**

Erasing all entries in a group

- 1 **[☒]** → **[MENU]**
- 2 **[↕]**: “Erase all” → **[SELECT]**
- 3 **[↕]**: Select the desired group. → **[SELECT]**
- 4 **[↕]**: “Yes” → **[SELECT]**
- 5 **[↕]**: “Yes” → **[SELECT]**
- 6 **[OFF]**

Chain dial

This feature allows you to dial phone numbers in the phonebook while you are on a call. This feature can be used, for example, to dial a calling card access number or bank account PIN that you have stored in the phonebook, without having to dial manually.

- 1 During an outside call:
[MENU] → **[↕]**: “Phonebook” → **[SELECT]**
- 2 **[↕]**: Select the desired entry.
- 3 Press **[CALL]** to dial the number.

Note:

- When storing a calling card access number and your PIN in the phonebook as one phonebook entry, press **[PAUSE]** to add pauses after

the number and PIN as necessary (page 22).

- If you have rotary/pulse service, you need to press **[☒]** (TONE) before pressing **[MENU]** on the handset or **[☒]** on the base unit in step 1 to change the dialing mode temporarily to tone. When adding entries to the phonebook, we recommend adding **[☒]** (TONE) to the beginning of phone numbers you wish to chain dial (page 26).

Programmable settings

You can customize the unit by programming the following features using the handset. To access the features, there are 2 methods:

■ Scrolling through the display menus

- 1 **[MENU]**
- 2 Press **[▼]** or **[▲]** to select the desired main menu. → **[SELECT]**
- 3 Press **[▼]** or **[▲]** to select the desired item from the next sub-menus. → **[SELECT]**
- 4 Press **[▼]** or **[▲]** to select the desired setting. → **[SAVE]**
 - This step may vary depending on the feature being programmed.
 - To exit the operation, press **[OFF]**.

■ Using the direct command code

- 1 **[MENU]** → Enter the desired code.
Example: Press **[MENU][#][1][0][1]**.
- 2 Select the desired setting. → **[SAVE]**
 - This step may vary depending on the feature being programmed.
 - To exit the operation, press **[OFF]**.

Note:

- In the following table, < > indicates the default settings.
- In the following table,  indicates the reference page number.
- Display menu order and sub-menu may vary depending on your model.

Display the menu tree and direct command code table

Main menu:  "Caller list"

Operation	Code	
Viewing the caller list.	#213	41

Main menu:  "Answering device"

Sub-menu 1	Sub-menu 2	Settings	Code	
Play new msg. (msg.: message)	–	–	#323	48
Play all msg.	–	–	#324	48
Erase all msg.*1	–	–	#325	48

Programming

Sub-menu 1	Sub-menu 2	Settings	Code	
Greeting	Record greeting* ¹	–	#302	47
	Check greeting	–	#303	47
	Pre-recorded* ¹ (Reset to pre-recorded greeting)	–	#304	47
Settings	Ring count* ¹	2-7: 2-7 rings <4 rings> 0: Toll saver	#211	50
	Recording time* ¹	1: 1 min 3: <3 min> 0: Greeting only* ²	#305	50
	Remote code* ¹	<111>	#306	49
	Screen call	1: <On> 0: Off	#310	46
Answer on* ¹	–	–	#327	46
Answer off* ¹	–	–	#328	46

Main menu:  "V.M. access"^{*3} (V.M.: Voice Mail)

Operation	Code	
Listening to Voice Mail messages.	#330	53

Main menu:  "Intercom"

Operation	Code	
Paging the desired unit.	#274	54

Programming

Main menu:  "Bluetooth"

Sub-menu 1	Sub-menu 2	Settings	Code	
Link to cell – 1: Add new device ^{*4} (for CELL 1) – 2: Add new device ^{*4} (for CELL 2)	Connect ^{*1} / Disconnect ^{*1}	–	#6251 ^{*5} #6252 ^{*6}	18
	Ringer volume – Handset ^{*7}	0–6: Off–6 <6>	#6281 ^{*5} #6282 ^{*6}	22
	Ringer volume – Base unit ^{*1, *7}	0–6: Off–6 <1>	#*6281 ^{*5} #*6282 ^{*6}	22
	Ringer tone ^{*8, *9}	1–5: Tone 1–5 <Tone 2> ^{*5} <Tone 4> ^{*6} 6–0: Melody 1–5	#6291 ^{*5} #6292 ^{*6}	–
	Select unit to ring ^{*1}	1–6: Handset 1–6 *: <All>	#6271 ^{*5} #6272 ^{*6}	17
	Ring as cell (limited) ^{*1}	1: <On (with Talking CID)> 2: On (without Talking CID) 0: Off	#6141 ^{*5} #6142 ^{*6}	17
	Registration	–	#6241 ^{*5} #6242 ^{*6}	16
	Phonebook transfer	–	–	#618
Headset	Add new device ^{*4}	–	#621	44
	Connect ^{*1} / Disconnect ^{*1}	–	#622	44
	Registration	–	#621	44

Programming

Sub-menu 1	Sub-menu 2	Settings	Code	
Settings	Auto connect*1	1: <1 min> 2: 3 min 3: 5 min 4: 10 min 0: Off	#632	18
	Cell area code*1	-	#633	19
	Cell line only mode*1	1: On 0: <Off>	#157	18
	Cell line select	1: Cellphone 1*4 2: Cellphone 2*4 0: <Manual>	#634	19
	Set PIN*1	<0000>	#619	19
Deregistration*2	-	-	#134	20

Main menu:  "Set date & time"

Sub-menu 1	Sub-menu 2	Settings	Code	
Date and time*1	-	-	#101	15
Alarm	-	1: Once 2: Daily 0: <Off>	#720	36
Time adjustment*1, *10	-	1: <Caller ID auto> 0: Manual	#226	-

Programming

Main menu:  "Initial setting"

Sub-menu 1	Sub-menu 2	Settings	Code	
Ringer setting	Ringer volume – Handset ^{*3, *7}	0-6: Off-6 <6>	#160	22
	Ringer volume – Base unit ^{*1, *3, *7}	0-6: Off-6 <1>	#*160	22
	Ringer tone ^{*3, *8, *9, *11} (Handset)	1-5: Tone 1-5 <Tone 1> 6-0: Melody 1-5	#161	–
	Interrupt tone ^{*12}	1: <On> 0: Off	#201	25
	Night mode – On/Off	1: On 0: <Off>	#238	36
	Night mode – Start/End	<11:00 PM/06:00 AM>	#237	36
Set date & time	Date and time ^{*1}	–	#101	15
	Alarm	1: Once 2: Daily 0: <Off>	#720	36
	Time adjustment ^{*1, *10}	1: <Caller ID auto> 0: Manual	#226	–
Talking Caller ID (Talking Call Display)	Handset	1: <On> 0: Off	#162	39
	Base unit ^{*1}	1: On 0: <Off>	#*162	
Handset name	–	–	#104	37
Call block ^{*1}	–	–	#217	37
	Block w/o num ^{*1, *2} (Block calls without phone number)	1: On 0: <Off>	#240	38
Voice mail ^{*3}	Store VM access# ^{*1} (VM: Voice Mail)	–	#331	52
	VM tone detect ^{*1}	1: <On> 0: Off	#332	52
Message alert	–	1: <On> 0: Off	#340	51
LCD contrast (Display contrast)	–	1-6: Level 1-6 <3>	#145	–
Key tone ^{*13}	–	1: <On> 0: Off	#165	–

Programming

Sub-menu 1	Sub-menu 2	Settings	Code	
Auto talk ^{*14}	–	1: On 0: <Off>	#200	22
Set tel line ^{*3}	Set dial mode ^{*1}	1: Pulse 2: <Tone>	#120	15
	Set flash time ^{*1, *15}	0: 900 ms 1: <700 ms> 2: 600 ms 3: 400 ms 4: 300 ms 5: 250 ms *: 200 ms #: 160 ms 6: 110 ms 7: 100 ms 8: 90 ms 9: 80 ms	#121	23
	Set line mode ^{*1, *16}	1: A 2: 	#122	–
	C. WTG options ^{*1} (Call Waiting Deluxe options)	1: On 0: <Off>	#215	40
Privacy mode ^{*1}	–	1: On 0: <Off>	#194	24
Registration	Register handset	–	#130	38
	Deregistration ^{*2}	–	#131	38
Change language	Display	1: <English> 2: Français	#110	14
	Voice prompt ^{*1}	1: <English> 2: Français	#112	15

Main menu:  "Customer support"^{*17}

Operation	Code	
Displaying customer support Web address.	#680	–

- *1 If you program these settings using one of the handsets, you do not need to program the same item using another handset.
- *2 This menu is not displayed when scrolling through the display menus. It is only available in direct command code.
- *3 When the cellular line only mode is turned on, these menus are not displayed (page 18).
- *4 After the Bluetooth device is registered, the device name is displayed.
- *5 For CELL 1
- *6 For CELL 2
- *7 Ringer volume cannot be turned off for alarm, intercom calls, and paging.

Programming

- *8 If you select one of the melody ringer tones, the ringer tone continues to play for several seconds even if the caller has already hung up. You may either hear a dial tone or no one on the line when you answer the call.
- *9 The preset melodies in this product are used with permission of © 2009 Copyrights Vision Inc.
- *10 This feature allows the unit to automatically adjust the date and time each time caller information including date and time is received.
To turn this feature on, select “**Caller ID auto**”. To turn this feature off, select “**Manual**”. (Call Display subscribers only)
To use this feature, set the date and time first (page 15).
- *11 If you subscribe to a distinctive ring service, select a tone (tone 1 to 5). If you select a melody, you cannot distinguish lines by their ringers.
- *12 This tone lets you know when you receive an outside call while you are on another line or an intercom call. If you select “**On**”, the tone sounds 2 times.
- *13 Turn this feature off if you prefer not to hear key tones while you are dialing or pressing any keys, including confirmation tones and error tones.
- *14 If you subscribe to a Call Display service and want to view the caller’s information after lifting up the handset to answer a call, turn off this feature.
- *15 The flash time depends on your telephone exchange or host PBX. Contact your PBX supplier if necessary.
- *16 Generally, the line mode setting should not be changed. This setting automatically maintains receiver volume at the proper level depending on the current telephone line condition. Set the line mode to “**A**” if telephone line condition is not good.
- *17 The handset can display the Internet address where you can download the operating instructions or get further information for this product, using your computer.

Programming

Special programming

Alarm

An alarm sounds at the set time for 3 minutes once or daily. Alarm can be set for each handset.

Important:

- Set the date and time beforehand (page 15).

- 1 **[MENU]** **#** **7** **2** **0**
- 2 **[↕]**: Select the desired alarm option.
→ **[SELECT]**

Off	Turns alarm off. Go to step 7.
Once	An alarm sounds once at the set time.
Daily	An alarm sounds daily at the set time. Go to step 4.

- 3 Enter the desired month and date.
→ **[OK]**
- 4 Set the desired time.
- 5 **[AM/PM]**: Select “AM” or “PM”. → **[OK]**
- 6 **[↕]**: Select the desired alarm tone.
→ **[SELECT]**
 - We recommend selecting a different ringer tone from the one used for outside calls.
- 7 **[SELECT]** → **[OFF]**
 - When the alarm is set, ☎ is displayed.

Note:

- To stop the alarm, press **[OFF]** or place the handset on the base unit or charger.
- When the handset is in use, the alarm will not sound until the handset is in standby mode.

Night mode

Night mode allows you to select a period of time during which the handset will not ring for outside calls. This feature is useful for time periods when you do not want to be disturbed, for example, while sleeping. Night mode can be set for each handset.

Important:

- Set the date and time beforehand (page 15).
- We recommend turning the base unit ringer off (page 31, 33) in addition to turning the night mode on.
- If you have set the alarm, the alarm sounds even if the night mode is turned on.

Turning night mode on/off

- 1 **[MENU]** **#** **2** **3** **8**
- 2 **[↕]**: Select the desired setting. → **[SAVE]**
 - If you select “Off”, press **[OFF]** to exit.
- 3 Enter the desired hour and minute you wish to start this feature.
- 4 **[AM/PM]**: Select “AM” or “PM”. → **[OK]**
- 5 Enter the desired hour and minute you wish to end this feature.
- 6 **[AM/PM]**: Select “AM” or “PM”.
- 7 **[SAVE]** → **[OFF]**
 - When the night mode is set, 🌙 is displayed.

Changing the start and end time

- 1 **[MENU]** **#** **2** **3** **7**
- 2 Continue from step 3, “Turning night mode on/off”, page 36.

Changing the handset name

Each handset can be given a customized name ("Bob", "Kitchen", etc.). This is useful when you make intercom calls between handsets. You can also select whether or not the handset name is displayed in standby mode. The default setting is "No". If you select "Yes" without entering any handset name, "Handset 1" to "Handset 6" is displayed.

- 1 **[MENU][#][1][0][4]**
- 2 Enter the desired name (max. 10 characters; see the character table, page 26).
 - If not required, go to step 3.
- 3 **[SAVE]**
- 4 **[↕]**: Select the desired setting. → **[SELECT]** 2 times
- 5 **[OFF]**

Call block (Call Display subscribers only)

This feature allows the unit to reject calls when:

- the unit receives a call from a phone number stored in the call block list as unwanted ("Storing unwanted callers", page 37).
- the unit receives a call without phone number ("Blocking incoming calls without phone number", page 38).

When a call is received, the unit rings for a short time while the caller is being identified. If the phone number matches an entry in the call block list:

- cellular calls are rejected.
- landline calls are disconnected after the unit first sends out a busy tone to the caller.

Important:

- When the unit receives a call from a number that is stored in the call block

list or a call without a recognized phone number, the call is logged in the caller list (page 41) with **↕** after the call is disconnected.

Storing unwanted callers

You can store up to 30 phone numbers in the call block list.

Important:

- We recommend storing 10 digits (including an area code). If only 7 digits are stored, all numbers that have the same last 7 digits will be blocked.

■ **From the caller list:**

- 1 **[←]** CID
- 2 **[↕]**: Select the entry to be blocked.
 - To edit the number, press **[SELECT]**, then press **[EDIT]** repeatedly until the phone number is shown in the 10-digit format.
- 3 **[SAVE]**
- 4 **[↕]**: "Call block" → **[SELECT]**
- 5 **[↕]**: "Yes" → **[SELECT]**
- 6 Edit the phone number if necessary (24 digits max.).
- 7 **[SAVE]** → **[OFF]**

■ **By entering phone numbers:**

- 1 **[MENU][#][2][1][7]** → **[ADD]**
- 2 Enter the phone number (24 digits max.).
 - To erase a digit, press **[CLEAR]**.
- 3 **[SAVE]** → **[OFF]**

Programming

Blocking incoming calls without phone number

You can reject a call when no phone number is provided, such as a call just showing “Unavailable”.

- 1 **[MENU]#240**
- 2 **[↕]**: Select the desired setting. → **[SAVE]** → **[OFF]**

Viewing/editing/erasing call block numbers

- 1 **[MENU]#217**
- 2 **[↕]**: Select the desired entry.
 - To exit, press **[OFF]**.
- 3 **To edit a number:**
[EDIT] → Edit the phone number.
→ **[SAVE]** → **[OFF]**
To erase a number:
[ERASE] → **[↕]**: “Yes” →
[SELECT] → **[OFF]**

Note:

- When editing, press the desired dial key to add, **[CLEAR]** to erase.
- When viewing, “Block w/o num” is displayed if the blocking incoming calls without phone number feature is turned on. To turn the feature off: **[ERASE]** → **[v]** → **[SAVE]** → **[OFF]**

Registering a unit

Operating additional units

Additional handsets

Up to 6 handsets can be registered to the base unit.

Important:

- See page 4 for information on the available model.

Registering a handset to the base unit

The supplied handset and base unit are pre-registered. If for some reason the handset is not registered to the base unit, re-register the handset.

- 1 **Handset:**
[MENU]#130
- 2 **Base unit:**
Press and hold **[LOCATOR]** for about 5 seconds until the registration tone sounds.
 - If all registered handsets start ringing, press **[LOCATOR]** again to stop, then repeat this step.
 - The next step must be completed within 90 seconds.
- 3 **Handset:**
Press **[OK]**, then wait until a long beep sounds.

Note:

- While registering, “Base in registering” is displayed on all registered handsets.
- When you purchase an additional handset, refer to the additional handset’s installation manual for registration.

Deregistering a handset

A handset can cancel its own registration to the base unit, or other handsets registered to the same base unit. This allows the handset to end its wireless connection with the system.

- 1 **[MENU]#131**
 - All handsets registered to the base unit are displayed.
- 2 **[↕]**: Select the handset you want to cancel. → **[SELECT]**
- 3 **[↕]**: “Yes” → **[SELECT]**
- 4 **[OFF]**

Using Call Display service

Important:

- This unit is Call Display compatible. To use Call Display features, you must subscribe to a Call Display service. Contact your service provider/telephone company for details.

Call Display features

When an outside call is being received, the caller's name and phone number are displayed.

Caller information for the last 50 callers is logged in the caller list from the most recent call to the oldest.

- If the unit cannot receive caller information, the following is displayed:
 - “**Unavailable**”: The caller dials from an area which does not provide a Call Display service.
 - “**Private caller**”: The caller requests not to send caller information.
 - “**Long distance**”: The caller makes a long distance call.
- If the unit is connected to a PBX system, caller information may not be properly received. Contact your PBX supplier.

Missed calls

If a call is not answered, the unit treats it as a missed call. The display shows “**Missed call**”. This lets you know if you should view the caller list to see who called while you were away.

Note:

- Even when there are unviewed missed calls, “**Missed call**” disappears from the standby display if

the following operation is performed by one of the units:

- A handset is replaced on the base unit or charger.
- Pressing [**OFF**] on a handset.

Phonebook name display

When caller information is received and it matches a phone number stored in the phonebook, the stored name in the phonebook is displayed and logged in the caller list.

Talking Call Display

This feature lets you know who is calling without looking at the display.

To use this feature, you must:

- subscribe to a Call Display service of your service provider/telephone company.
- turn this feature on (page 33).

When caller information is received, the handsets and base unit announce the caller's name or phone number received from your service provider/telephone company following every ring.

- Name pronunciation may vary. This feature may not pronounce all names correctly.
- Call Display service has a limit of how many characters can be displayed. If the caller's name is too long, the handset may not be able to display or announce the entire name.
- The announcement is heard at the same level as the ringer volume (page 31, 33).
- If you turn on the answering system and set the number of rings “**2 rings**” (page 50), the unit does not announce the caller information from the landline. If “**Toll saver**” is selected and there is a new message, the unit does not announce the caller information from the landline.

Call Display Service

- When you receive a call while on the phone, the 2nd caller's name is not announced even if you subscribe to both Call Display and Visual Call Waiting services.

Phonebook name announcement

When caller information is received and it matches a phone number stored in the phonebook, the stored name in the phonebook is announced.

Ringer ID

You can select the desired ringer tone to a group that each phonebook entry is assigned (page 27). When a call is received from a caller assigned to a group, the ringer tone you selected for that group rings instead of the called line's ringer tone (page 17, 31, 33) after caller information is displayed. If you select "Current ringer" (default), the unit uses the called line's ringer tone when calls from this group are received.

- 1 **[📖] → [MENU]**
- 2 **[↕]: "Group" → [SELECT]**
- 3 **[↕]: Select the desired group. → [SELECT]**
- 4 **[↕]: Select the desired ringer tone. → [SAVE]**
- 5 **[OFF]**

For Call Waiting Deluxe service users

To use Call Waiting Deluxe, you must subscribe to Call Waiting Deluxe from your service provider/telephone company.

This feature not only allows the unit currently in use to display the 2nd caller's information, but also offers you a variety of ways to deal with the 2nd call.

Important:

- Please contact your service provider/telephone company for details and availability of this service in your area.
- This feature must be turned on before it can be used.

To turn Call Waiting Deluxe on/off

To use Call Waiting Deluxe, you must turn this feature on. The default setting is "Off".

- 1 **[MENU]#215**
- 2 **[↕]: Select the desired setting.**
- 3 **[SAVE] → [OFF]**

Call Waiting Deluxe service options

When a 2nd call is received, you can choose how to handle the call by selecting an option shown on the unit display.

Note:

- Your service provider/telephone company may not offer all of the options (page 40).

Displayed option	Function
Answer	Answers the waiting call, while keeping the 1st call on hold.
Hold	Holds the waiting call. The caller will hear the prerecorded hold message played by your service provider/telephone company.

Call Display Service

Displayed option	Function
Announce	The caller will hear the pre-recorded busy message played by your service provider/ telephone company (for example, "We are not available now.") and will then be disconnected.
Forward	Forwards the waiting call to the Voice Mail service provided by your service provider/ telephone company. You must subscribe to Voice Mail service to use this function.
Drop	Disconnects (drops) the current call and answers the waiting call.
Conference	Answers the waiting call and combines it with the current call to make a conference call (3-party call).
Return	Returns to the waiting caller while keeping the current call on hold.
Drop caller1	Disconnects (drops) the 1st call during a conference call.
Drop caller2	Disconnects (drops) the 2nd call during a conference call.

To use Call Waiting Deluxe service

- When you hear a Call Waiting tone during an outside call, press **[FLASH]**.
 - The option menu is displayed.

- [↕]**: Select the desired option. → **[SELECT]**
 - After selecting "Answer", "Hold", or "Conference", you can select another option. → **[FLASH]** → **[↕]**: Select the desired option. → **[SELECT]**

Note:

- To exit from the option menu, wait for 20 seconds.

Caller list

Important:

- Only 1 person can access the caller list at a time.
- Make sure the unit's date and time setting is correct (page 15).

Viewing the caller list and calling back

■ Using a cellular line

- [←]** CID
- Press **[▼]** to search from the most recent call, or **[▲]** to search from the oldest call.
- To call back, press **[SELECT]**. To exit, press **[OFF]**.
- [CELL]**
 - The unit starts dialing when:
 - only 1 cellular phone is registered.
 - a specific line is set to make cellular calls (page 19).
- [↕]**: Select the desired cellular phone. → **[SELECT]**

■ Using the landline

- [←]** CID
- Press **[▼]** to search from the most recent call, or **[▲]** to search from the oldest call.

Call Display Service

- 3** To call back, press **[↶]**.
To exit, press **[OFF]**.

Note:

- If the entry has already been viewed or answered, “✓” is displayed, even if it was viewed or answered using another unit.
- In step 2, if **▶** is displayed, not all of the information is shown. To see the remaining information: Press **[▶]**. To return to the previous screen, press **[◀]**.
- **☑** or **☒** indicates the caller information was received from the cellular line.

Editing a caller's phone number before calling back

You can edit a phone number in the caller list by adding the long distance code “1” or removing its area code.

- 1** **[◀]** CID
- 2** **[↕]**: Select the desired entry.
- 3** Press **[SELECT]**, then press **[EDIT]** repeatedly until the phone number is shown in the desired format.
 - ① 1 – Area code – Local phone number
Example: 1-555-321-5555
 - ② Local phone number
Example: 321-5555
 - ③ Area code – Local phone number
Example: 555-321-5555
- 4 Using a cellular line:**
To make a cellular call, continue from step 4, “Viewing the caller list and calling back”, page 41.
Using the landline:
[↶]

Note:

- The number edited in step 3 will not be saved in the caller list.

Erasing selected caller information

- 1** **[◀]** CID
- 2** **[↕]**: Select the desired entry.
- 3** **[ERASE]** → **[↕]**: “Yes”
- 4** **[SELECT]** → **[OFF]**

Erasing all caller information

- 1** **[◀]** CID
- 2** **[ERASE]** → **[↕]**: “Yes”
- 3** **[SELECT]** → **[OFF]**

Storing caller information to the phonebook

- 1** **[◀]** CID
- 2** **[↕]**: Select the desired entry.
 - To edit the number, press **[SELECT]**, then press **[EDIT]** repeatedly until the phone number is shown in the desired format.
- 3** **[SAVE]**
- 4** **[↕]**: “Phonebook” → **[SELECT]**
- 5** Continue from step 3, “Editing entries”, page 27.

Copying phonebook from a cellular phone (phonebook transfer)

You can copy phonebook entries from the registered cellular phones or other cellular phones (not registered) to the unit's shared phonebook. A cellular phone must be Bluetooth wireless technology compatible.

Important:

- If a copied entry has 2 or more phone numbers, each phone number (6 max.) is stored as a separate entry with the same name.
- If a phonebook entry includes additional data such as a picture, that entry may fail to copy to the base unit.

1 Handset:

[MENU][#][6][1][8]

2 Handset:

To copy from registered cellular phones:

[↕]: Select the desired cellular phone. → [SELECT]

- Copied items are stored to the group ("Cell 1" or "Cell 2") which the cellular phone is registered to.

To copy from other cellular phones (not registered):

[↕]: "Other cell" → [SELECT]

→ [↕]: Select the group you want to copy to. → [SELECT]

3 When "Transfer phonebook from cell." is displayed:

Go to step 4.

When "Select mode" menu is displayed:

[↕]: Select "Auto" or "Manual".
→ [SELECT]

"Auto": Download all entries from the cellular phone automatically. Go to step 5.

"Manual": Copy entries you selected.

- "Select mode" menu is displayed only when the cellular phone supports PBAP (Phone Book Access Profile) for Bluetooth connection.

4 Cellular phone:

Follow the instructions of your cellular phone to copy phonebook entries.

- For other cellular phones (not registered), you need to search for and select the base unit. The base unit PIN (default: "0000") may be required.
- The entries being copied are displayed on the handset.

5 Handset:

Wait until "Completed" is displayed.

- You can continue copying other entries if necessary.

6 Handset: [OFF]

Note:

- Some copied entries may have characters which do not exist in the character table (page 26). These characters can be displayed but cannot be entered when editing an entry.
- The unit does not support some characters. If a copied entry includes those characters, they are replaced with other available characters or "*".
- If you receive a call while copying phonebook entries, the copying procedure stops. Try again after finishing the call.

Using Bluetooth Devices

Using a Bluetooth wireless headset (optional) for landline calls

By registering a Bluetooth headset to the base unit, you can have a hands-free conversation wirelessly for landline calls.

Important:

- 1 headset can be registered to the base unit. However, only one Bluetooth device (cellular phone or headset) can be connected to the base unit at a time.
- For best performance, we recommend using a Bluetooth headset within 1 m (3.3 feet) of the base unit. A headset can communicate with the base unit within a range of approximately 10 m (33 feet).

Registering a headset to the base unit

Important:

- Make sure that the Bluetooth headset is not connected to any other Bluetooth device.

1 Your headset:

Set your headset to registration mode.

- Refer to the headset operating instructions.

2 Handset:

[MENU][#][6][2][1]

3 Enter your headset PIN.

- Typically, default PIN is "0000". Refer to the headset operating instructions.

4 Press **[OK]**, then wait until a long beep sounds.

5 **[OFF]**

- When the HEADSET indicator on the base unit lights green, you are ready to use the headset.

Connecting/disconnecting a headset

If you cannot connect the headset and base unit using the headset, you can connect using the unit.

To use your headset with another Bluetooth device such as a cellular phone, you may need to disconnect it from the base unit.

Important:

- Make sure that the headset is turned on.

1 To connect/disconnect:

[MENU][#][6][2][2]

- A long beep sounds.

2 **[OFF]**

Deregistering a headset

You can cancel a registration of the headset that is stored to the base unit. See "Deregistering Bluetooth devices", page 20.

Operating a Bluetooth wireless headset using a landline

Important:

- Refer to your headset operating instructions for headset operations.

Answering landline calls with your headset

To answer a landline call, turn on your headset referring to your headset operating instructions.

When you finish talking, turn off your headset referring to your headset operating instructions.

Note:

- If you cannot hang up the call using your headset, press **[■]** (STOP) on the base unit.

Switching from the base unit to your headset

While listening to messages recorded on the base unit answering system, you can only switch from the base unit to your headset. Turn on the headset referring to your headset operating instructions.

Call sharing between your headset and the handset**Important:**

- To activate this feature, you should set privacy mode to off beforehand (page 34).

■ While the handset is on a landline call:

To join the conversation with your headset, turn on the headset referring to your headset operating instructions.

■ While your headset is on a landline call:

To join the conversation with the handset, press **[↶]**.

Adjusting your headset receiver volume** Base unit**

Press **[+]** or **[-]** repeatedly while using your headset.

Answering system for landline

The answering system can answer and record calls for you when you are unavailable to answer the phone. You can also set the unit to play a greeting message but not to record caller messages by selecting “Greeting only” as the recording time setting (page 50).

Important:

- Only 1 person can access the answering system (listen to messages, record a greeting message, etc.) at a time.
- When callers leave messages, the unit records the day and time of each message. Make sure the date and time have been set correctly (page 15).
- When the cellular line only mode is set (page 18), the answering system cannot be used and any messages are not received.

Memory capacity (including your greeting message)

The total recording capacity is about 16 minutes. A maximum of 64 messages can be recorded.

Note:

- When message memory becomes full:
 - “Messages full” is shown on the handset display.
 - The ANSWER ON/OFF indicator on the base unit flashes rapidly if the answering system is turned on.
 - The message counter on the base unit flashes if the answering system is turned on.
 - If you use the pre-recorded greeting message, the unit automatically

switches to another pre-recorded greeting message asking callers to call again later.

- If you recorded your own greeting message, the same message is still announced to callers even though their messages are not recorded.

Turning the answering system on/off

Base unit

Press **[ANSWER ON/OFF]** to turn on/off the answering system.

Handset

- 1 **To turn on:**
[MENU]#327
To turn off:
[MENU]#328
- 2 **[OFF]**

Note for base unit and handset:

- When the answering system is turned on:
 - The ANSWER ON/OFF indicator on the base unit lights up.
 - The message counter on the base unit displays the total number of messages (old and new).

Call screening

While a caller is leaving a message, you can listen to the call through the unit's speaker.

To adjust the speaker volume, press **[▲]** or **[▼]** repeatedly. You can answer the call by pressing **[hook]**. Call screening can be set for each handset. The default setting is “on”.

- 1 **[MENU]#310**
- 2 **[↕]**: Select the desired setting. → **[SAVE]** → **[OFF]**

Greeting message

When the unit answers a call, a greeting message is played to callers.

You can use either:

- your own greeting message
- a pre-recorded greeting message

Recording your greeting message

- 1 **[MENU]** **[#]** **[3]** **[0]** **[2]**
- 2 **[↕]**: “Yes” → **[SELECT]**
- 3 After a beep sounds, hold the handset about 20 cm (8 inches) away and speak clearly into the microphone (2 minutes max.).
- 4 Press **[STOP]** to stop recording.
- 5 **[OFF]**

Using a pre-recorded greeting message

The unit provides 2 pre-recorded greeting messages:

- If you erase or do not record your own greeting message, the unit plays a pre-recorded greeting asking callers to leave a message.
- If the message recording time (page 50) is set to “Greeting only”, callers’ messages are not recorded and the unit plays a different pre-recorded greeting message asking callers to call again.

Resetting to a pre-recorded greeting message

If you want to use a pre-recorded greeting message once you record your own greeting message, you need to erase your own greeting message.

- 1 **[MENU]** **[#]** **[3]** **[0]** **[4]**
- 2 **[YES]** → **[OFF]**

Playing back the greeting message

- 1 **[MENU]** **[#]** **[3]** **[0]** **[3]**
- 2 **[OFF]**

Listening to messages using the base unit

When new messages have been recorded:

- **[▶]** on the base unit flashes.
- Press **[▶]**.
 - If new messages have been recorded, the base unit plays back new messages.
 - If there are no new messages, the base unit plays back all messages.

Operating the answering system during playback

Key	Operation
[+] or [-]	Adjust the speaker volume
[◀◀]	Repeat message*1
[▶▶]	Skip message
[■] (STOP)	Stop playback
[ERASE]	Erase currently playing message

*1 If pressed within the first 5 seconds of a message, the previous message is played.

Erasing all messages

Press **[ERASE]** 2 times while the unit is not in use.

Answering System for Landline

Listening to messages using the handset

When new messages have been recorded:

- “New message” is displayed.
- The message indicator on the handset flashes slowly if the message alert feature is turned on (page 51).

1 To listen to new messages:
[MENU] → [PLAY]

or

[MENU]#|3|2|3

To listen to all messages:

[MENU]#|3|2|4

2 When finished, press [OFF].

Note:

- To switch to the receiver, press [↶].

Operating the answering system

[MENU] → [↕]: “Answering device” → [SELECT]

Key	Operation
[▲] or [▼]	Adjust the receiver/speaker volume (during playback)
1 or [◀]	Repeat message (during playback)*1
2 or [▶]	Skip message (during playback)
3	Enter the “Settings” menu
4	Play new messages
5	Play all messages
6	Play greeting message
7 6	Record greeting message
8	Turn answering system on
[PAUSE]	Pause message*2

Key	Operation
9 or [STOP]	Stop recording Stop playback
0	Turn answering system off
* 4	Erase currently playing message
* 5	Erase all messages
* 6	Reset to a pre-recorded greeting message

*1 If pressed within the first 5 seconds of a message, the previous message is played.

*2 To resume playback:

[↕]: “Playback” → [SELECT]

*3 You can also erase as follows:

[ERASE] → [↕]: “Yes” → [SELECT]

Calling back (Call Display subscribers only)

If caller information is received for the call, you can call the caller back while listening to a message.

1 Press [PAUSE] during playback.

2 [↕]: “Call back” → [SELECT]

Editing the number before calling back

1 Press [PAUSE] during playback.

2 [↕]: “Edit & Call” → [SELECT]

3 Press [EDIT] repeatedly until the phone number is shown in the desired format (page 42). → [↶]

- To call back using a cellular line, continue from step 2, “Making cellular calls”, page 21.

Erasing all messages

1 [MENU]#|3|2|5

2 [↕]: “Yes” → [SELECT] → [OFF]

Remote operation

Using a touch-tone phone, you can call your phone number from outside and access the unit to listen to messages or change answering system settings. The unit's voice guidance prompts you to press certain dial keys to perform different operations.

Remote access code

A 3-digit remote access code must be entered when operating the answering system remotely. This code prevents unauthorized parties from listening to your messages remotely. The default setting is "111".

Important:

- To prevent unauthorized access to this product, we recommend that you regularly change the remote code.

- 1 **[MENU]** **#** **[3]** **[0]** **[6]**
- 2 Enter the desired 3-digit remote access code.
- 3 **[SAVE]** → **[OFF]**

Deactivating remote operation

Press **[*]** in step 2 on "Remote access code", page 49.

- The entered remote access code is deleted.

Using the answering system remotely

- 1 Dial your landline phone number from a touch-tone phone.
- 2 After the greeting message starts, enter your remote access code.
- 3 Follow the voice guidance prompts as necessary or control the unit using remote commands (page 49).

- 4 When finished, hang up.

Voice guidance

During remote operation, the unit's voice guidance starts and prompts you to press **[1]** to perform a specific operation, or press **[2]** to listen to more available operations.

Note:

- If you do not press any dial keys within 10 seconds after a voice guidance prompt, the unit disconnects your call.

Remote commands

You can press dial keys to access certain answering system functions without waiting for the voice guidance to prompt you.

Key	Operation
[1]	Repeat message (during playback)*1
[2]	Skip message (during playback)
[4]	Play new messages
[5]	Play all messages
[9]	Stop playback
[0]	Turn answering system off
[*][4]	Erase currently playing message
[*][5]	Erase all messages
[*][#]	End remote operation (or hang up)

*1 If pressed within the first 5 seconds of a message, the previous message is played.

Answering System for Landline

Turning on the answering system remotely

If the answering system is off, you can turn it on remotely.

- 1 Dial your phone number from a touch-tone phone.
- 2 Let the phone ring 15 times.
 - A long beep is heard.
- 3 Enter your remote access code within 10 seconds after the long beep.
 - The greeting message is played back.
 - You can either hang up, or enter your remote access code again and begin remote operation (page 49).

Answering system settings

Number of rings before the unit answers a call

You can change the number of times the phone rings “**Ring count**” before the unit answers calls. You can select 2 to 7 rings, or “**Toll saver**”.

The default setting is “**4 rings**”.

“**Toll saver**”: The unit's answering system answers at the end of the 2nd ring when new messages have been recorded, or at the end of the 5th ring when there are no new messages. If you call your phone from outside to listen to new messages (page 49), you know that there are no new messages when the phone rings for the 3rd time. You can then hang up without being charged for the call.

- 1 **[MENU]** **#** **2** **1** **1**
- 2 **[↕]**: Select the desired setting. → **[SAVE]** → **[OFF]**

For Voice Mail service subscribers

If you subscribe to a flat-rate service package that includes Call Display, Call Waiting, Voice Mail, and Unlimited Local/Regional/Long distance calls, please note the following:

- To use the Voice Mail service provided by your service provider/telephone company rather than the unit's answering system (page 46).
- To use this unit's answering system rather than the Voice Mail service provided by your service provider/telephone company, please contact your service provider/telephone company to deactivate your Voice Mail service.

If your service provider/telephone company cannot do this:

- Set this unit's “**Ring count**” setting so that this unit's answering system answers calls before the Voice Mail service of your service provider/telephone company does. It is necessary to check the number of rings required to activate the Voice Mail service provided by your service provider/telephone company before changing this setting.
- Change the number of rings of the Voice Mail service so that the answering system can answer the call first. To do so, contact your service provider/telephone company.

Caller's recording time

You can change the maximum message recording time allowed for each caller.

The default setting is “**3 min**”.

- 1 **[MENU]** **#** **3** **0** **5**
- 2 **[↕]**: Select the desired setting. → **[SAVE]** → **[OFF]**

Selecting “Greeting only”

You can select “Greeting only” which sets the unit to announce a greeting message to callers but not record messages.

Select “Greeting only” in step 2 on “Caller’s recording time”, page 50.

Note:

- When you select “Greeting only”:
 - If you do not record your own message, the unit will play the pre-recorded greeting-only message asking callers to call again later.
 - If you use your own message, record the greeting-only message asking callers to call again later (page 47).

Message alert

You can select whether or not the message indicator on the handset flashes slowly when new messages are recorded. The default setting is “On”.

Important:

- If you stored the Voice Mail access number (page 52), the message indicator also flashes for newly recorded Voice Mail messages from the landline (page 53).

1 [MENU]#340

2 [↕]: Select the desired setting. →
[SAVE] → [OFF]

Note:

- While message alert is on, battery operating time is shortened (page 10).

Voice Mail Service for Landline

Voice Mail service for landline

Voice Mail is an automatic answering service offered by your service provider/telephone company. After you subscribe to this service, your service provider/telephone company's Voice Mail system answers calls for you when you are unavailable to answer the phone or when your line is busy. Messages are recorded by your service provider/telephone company, not your telephone. Please contact your service provider/telephone company for details of this service.

Important:

- To use the Voice Mail service provided by your service provider/telephone company rather than the unit's answering system, turn off the answering system (page 46). For details, see page 50.
- You need to store the Voice Mail access number to activate the message alert feature (page 51) for Voice Mail service.

Storing the Voice Mail (VM) access number

In order to listen to your Voice Mail messages, you must dial your service provider/telephone company's Voice Mail access number. Once you have stored your Voice Mail access number, you can dial it automatically (page 53).

- 1 **[MENU]#[3][3][1]**
- 2 Enter your access number (24 digits max.). → **[SAVE]** → **[OFF]**

Note:

- When storing your Voice Mail access number and your mailbox password, press **[PAUSE]** to add pauses

(page 22) between the access number and the password as necessary. Contact your service provider/telephone company for the required pause time.

Example:

1-222-333-4444	PPPP	8888
VM access number	Pauses	Password

To erase the Voice Mail access number

- 1 **[MENU]#[3][3][1]**
- 2 Press and hold **[CLEAR]** until all digits are erased. → **[SAVE]** → **[OFF]**

Voice Mail (VM) tone detection

Your service provider/telephone company sends special signals (sometimes called "Voice Mail tones" or "stutter tones") to the unit to let you know you have new Voice Mail messages. If you hear a series of dial tones followed by a continuous dial tone after you press **[📞]**, you have new Voice Mail messages. Soon after you hang up a call or after the phone stops ringing, your unit checks the phone line to see if new Voice Mail messages have been recorded.

Turn this feature off when:

- You do not subscribe to Voice Mail service.
 - Your service provider/telephone company does not send Voice Mail tones.
 - Your phone is connected to a PBX.
- If you are not sure which setting is required, contact your service provider/telephone company.

Turning VM tone detection on/off

The default setting is “on”.

- 1 **[MENU][#][3][3][2]**
- 2 **[↕]**: Select the desired setting. →
[SAVE] → [OFF]

Listening to Voice Mail messages

The unit lets you know that you have new Voice Mail messages in the following ways:

- “**New Voice Mail**” is displayed on the handset if message indication service is available.
- The message indicator on the handset flashes slowly if the message alert feature is turned on (“Message alert”, page 51).

- 1 **[MENU][#][3][3][0]**
 - The speakerphone turns on.
- 2 Follow the pre-recorded instructions.
- 3 When finished, press **[OFF]**.

Note:

- If the handset still indicates there are new messages even after you have listened to all new messages, turn it off by pressing and holding **[#]** until the handset beeps.
- If your Voice Mail service uses Voice Mail tones and a message is over 3 minutes long, the handset may not indicate new messages.
- If your Voice Mail service uses Voice Mail tones, the tones are heard from any phone connected to the same line. If you want to use another phone to listen to Voice Mail messages, you have to dial your access number manually.

Intercom/Locator

Intercom

Intercom calls can be made between handsets.

Note:

- If you receive an outside call while talking on the intercom, you hear 2 tones. To answer the call, press [OFF], then press [↶].
- When paging the handset, the paged handset beeps for 1 minute.

Making an intercom call

- 1 [MENU] → [INT]
- 2 [↕]: Select the desired unit. → [SELECT]
 - To stop paging, press [OFF].
- 3 When you finish talking, press [OFF].

Answering an intercom call

- 1 Press [↶] to answer the page.
- 2 When you finish talking, press [OFF].

Handset locator

You can locate a misplaced handset by paging it.

- 1 **Base unit:**
Press [LOCATOR].
 - All registered handsets beep for 1 minute.
- 2 To stop paging:
Base unit:
Press [LOCATOR].
Handset:
Press [OFF].

Transferring calls, conference calls

Outside calls can be transferred or a conference call with an outside party can be made between 2 handsets.

- 1 During an outside call, press [INT] to put the call on hold.
- 2 [↕]: Select the desired unit. → [SELECT]
- 3 Wait for the paged party to answer.
 - If the paged party does not answer, press [↶] to return to the outside call.
- 4 **To complete the transfer:**
Press [OFF].
 - The outside call is being routed to the destination unit.**To establish a conference call:**
[MENU] → [↕]: "Conference" → [SELECT]
 - To leave the conference, press [OFF]. The other 2 parties can continue the conversation.
 - To put the outside call on hold: [MENU] → [↕]: "Hold" → [SELECT]
To resume the conference: [MENU] → [↕]: "Conference" → [SELECT]

Answering a transferred call

Press [↶] to answer the page.

Wall mounting

Note:

- Make sure that the wall and the fixing method are strong enough to support the weight of the unit.

Base unit

- 1 Lead the AC adaptor cord and telephone line cord through the hole in the wall mounting adaptor in the direction of the arrow.

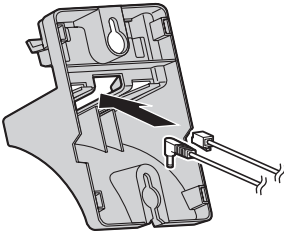

- 2 Tuck the telephone line cord inside the wall mounting adaptor (1). Connect the AC adaptor cord and telephone line cord (2).

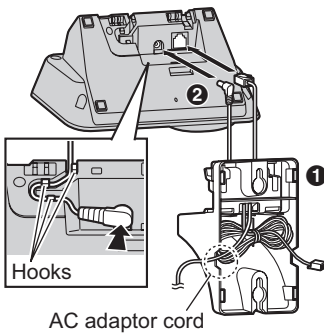

- 3 Insert the hooks on the wall mounting adaptor into holes A and B on the base unit.

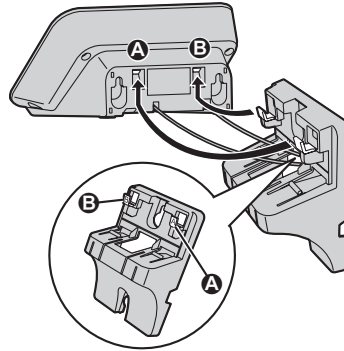

- 4 Adjust the adaptor to hold the base unit, then push it in the direction of the arrow until it clicks into place.

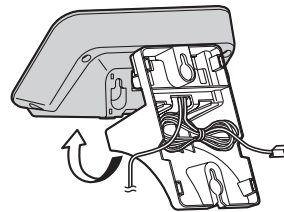
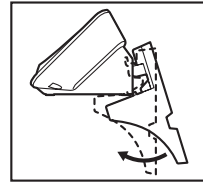

Useful Information

- 5** Mount the unit on a wall then slide down to secure in place.

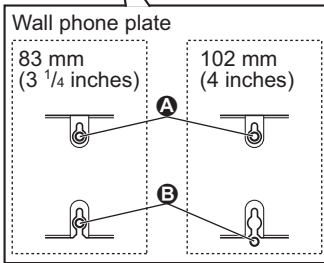
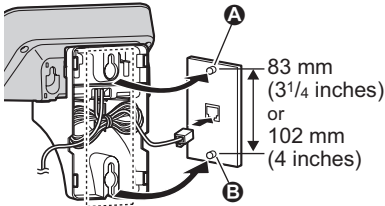
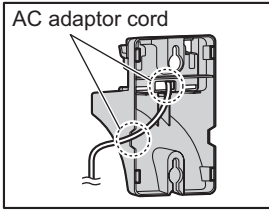

To remove the wall mounting adaptor

While pushing down the release levers (1), remove the adaptor (2).

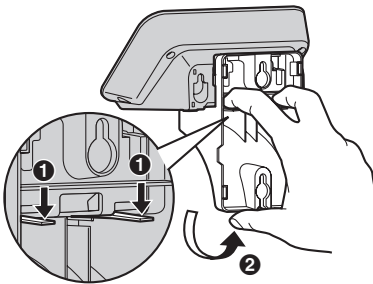

Charger

Drive the screws (not supplied) into the wall.

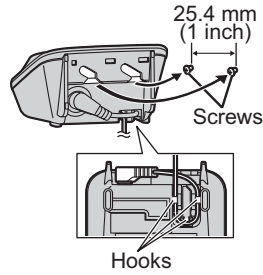

Error messages

Display message	Cause/solution
Access # to VM service is not stored	<ul style="list-style-type: none"> You have not stored the Voice Mail access number. Store the number (page 52).
Base no power or No link. Re-connect base AC adaptor.	<ul style="list-style-type: none"> The handset has lost communication with the base unit. Move closer to the base unit and try again. Unplug the base unit's AC adaptor to reset the unit. Reconnect the adaptor and try again. The handset's registration may have been canceled. Re-register the handset (page 38).
Busy	<ul style="list-style-type: none"> No cellular phone is registered to the base unit. Register a cellular phone (page 16). The called unit is in use. Other units are in use and the system is busy. Try again later. The handset you are using is too far from the base unit. Move closer and try again.
Check tel line	<ul style="list-style-type: none"> The supplied telephone line cord has not been connected yet or not connected properly. Check the connections (page 9). If you do not connect the telephone line cord and use only cellular lines, set the cellular line only mode (page 18).
Error!!	<ul style="list-style-type: none"> Recording was too short. Try again. Someone is using a cellular line or headset. Try again later. The phonebook copy is incomplete (page 43). The cellular phone is disconnected from the base unit. Make sure that other Bluetooth devices are not connected to the cellular phone and try again.
Failed	<ul style="list-style-type: none"> Although the unit tried to connect to the cellular phone or headset, the connection has failed. <ul style="list-style-type: none"> Someone is using a cellular line or headset. Try again later. Make sure that the cellular phone or headset is not connected to other Bluetooth devices.

Useful Information

Display message	Cause/solution
Invalid	<ul style="list-style-type: none">• There is no handset registered to the base unit matching the handset number you entered.• The handset is not registered to the base unit. Register the handset (page 38).
Requires subscription to Caller ID.	<ul style="list-style-type: none">• You must subscribe to a Call Display service. Once you receive caller information after subscribing to a Call Display service, this message will not be displayed.
Use rechargeable battery.	<ul style="list-style-type: none">• A wrong type of battery such as Alkaline or Manganese was inserted. Use only the rechargeable Ni-MH batteries noted on page 4, 6.

Troubleshooting

If you still have difficulties after following the instructions in this section, disconnect the base unit's AC adaptor, then reconnect the base unit's AC adaptor. Remove the batteries from the handset, and then insert the batteries into the handset again.

General use

Problem	Cause/solution
The handset does not turn on even after installing charged batteries.	<ul style="list-style-type: none">• Place the handset on the base unit or charger to turn on the handset.
The unit does not work.	<ul style="list-style-type: none">• Make sure the batteries are installed correctly (page 9).• Fully charge the batteries (page 10).• Check the connections (page 9).• Unplug the base unit's AC adaptor to reset the unit. Reconnect the adaptor and try again.• The handset has not been registered to the base unit. Register the handset (page 38).

Useful Information



Problem	Cause/solution
I cannot register a cellular phone to the base unit.	<ul style="list-style-type: none"> ● Depending on the compatibility of the cellular phone, you may not be able to register it to the base unit. Confirm that your cellular phone supports the hands-free profile (HFP) specification. ● Confirm that the Bluetooth feature of your cellular phone is turned on. You may need to turn this feature on depending on your cellular phone. ● The Bluetooth technology on your cellular phone may not be functioning normally. Turn off and on your cellular phone. ● If your cellular phone is already connected to another Bluetooth device such as a Bluetooth headset, turn it off or disconnect it from your cellular phone. ● Some cellular phones may require you to enter the base unit PIN to register. Confirm that you entered the correct PIN.
I cannot connect a cellular phone to the base unit.	<ul style="list-style-type: none"> ● Confirm that your cellular phone is turned on. ● Confirm that your cellular phone is within base unit range (page 13). ● Depending on the state of the wireless environment, such as the presence of any electrical interference, there may be a delay even if the auto connection feature is turned on. You can connect to the base unit manually (page 18). ● The cellular phone has not been registered to the base unit. Register the cellular phone (page 16).
I cannot hear a dial tone.	<ul style="list-style-type: none"> ● Make sure the base unit's AC adaptor is connected properly (page 9). ● Make sure that the CELL 1 or CELL 2 indicator lights green (page 13). ● Make sure the telephone line cord is connected properly (page 9). ● Disconnect the base unit from the telephone line and connect the line to a known working telephone. If the working telephone operates properly, contact our service personnel to have the unit repaired. If the working telephone does not operate properly, contact your service provider/ telephone company.
The indicator on the handset flashes slowly.	<ul style="list-style-type: none"> ● New messages have been recorded. Listen to the new messages (page 48). ● New Voice Mail messages have been recorded. Listen to the new Voice Mail messages (page 53).

Useful Information

Programmable settings

Problem	Cause/solution
The display is in a language I cannot read.	<ul style="list-style-type: none">● Change the display language (page 14).
I cannot register a handset to a base unit.	<ul style="list-style-type: none">● The maximum number of handsets (6) is already registered to the base unit. Cancel unused handset registrations from the base unit (page 38).

Battery recharge

Problem	Cause/solution
The handset beeps and/or  flashes.	<ul style="list-style-type: none">● Battery charge is low. Fully charge the batteries (page 10).
I fully charged the batteries, but <ul style="list-style-type: none">–  still flashes,–  is displayed, or– the operating time seems to be shorter.	<ul style="list-style-type: none">● Clean the battery ends (\oplus, \ominus) and the charge contacts with a dry cloth and charge again.● It is time to replace the batteries (page 9).

Making/answering calls, intercom

Problem	Cause/solution
 is displayed.	<ul style="list-style-type: none">● The handset is too far from the base unit. Move closer.● The base unit's AC adaptor is not properly connected. Reconnect AC adaptor to the base unit.● The handset is not registered to the base unit. Register it (page 38).
Noise is heard, sound cuts in and out.	<ul style="list-style-type: none">● You are using the handset or base unit in an area with high electrical interference. Re-position the base unit and use the handset away from sources of interference.● Move closer to the base unit.● If you use a DSL/ADSL service, we recommend connecting a DSL/ADSL filter between the base unit and the telephone line jack. Contact your DSL/ADSL provider for details.

Useful Information

Problem	Cause/solution
The handset or base unit does not ring.	<ul style="list-style-type: none"> ● The ringer volume is turned off. Adjust the ringer volume (page 31, 33). ● When one handset is selected to ring for cellular calls, other units do not ring. To change the selection, see page 17. ● Night mode is turned on for the handset. Turn it off (page 36).
I cannot make local calls with the handset or base unit using a cellular line.	<ul style="list-style-type: none"> ● You need to add your area code when making cellular calls. Store your area code in order to automatically add it to the beginning of the 7-digit phone number when making cellular calls (page 19).
I cannot make or answer cellular calls with the handset or base unit.	<ul style="list-style-type: none"> ● Depending on the cellular phone's compatibility, you may not be able to make or answer cellular calls even if the cellular phone is connected to the base unit. ● Make sure that the CELL 1 or CELL 2 indicator lights green and the cellular phone is connected to the base unit (page 18). ● If someone is talking on a cellular call or using the headset, you cannot use the cellular feature. There can be only one active Bluetooth connection at a time. ● The cellular phone is being used separately from your system.
I can make and answer cellular calls but cannot hear a sound.	<ul style="list-style-type: none"> ● The Bluetooth technology on your cellular phone may not be functioning normally. Turn off and on your cellular phone. ● Disconnect and reconnect the base unit AC adaptor and try again.
I cannot switch cellular calls from the unit to the cellular phone.	<ul style="list-style-type: none"> ● Your cellular phone may not support this feature. Refer to the operating instructions of your cellular phone.
I cannot make a call using the landline.	<ul style="list-style-type: none"> ● The dialing mode may be set incorrectly. Change the setting (page 15). ● The handset is too far from the base unit. Move closer and try again. ● The cellular line only mode is turned on. Turn it off (page 18).
I cannot make long distance calls.	<ul style="list-style-type: none"> ● Make sure that you have long distance service.

Useful Information

Call Display/Talking Call Display

Problem	Cause/solution
Caller information is not displayed.	<ul style="list-style-type: none">● You must subscribe to Call Display service. Contact your service provider/telephone company for details.● If your unit is connected to any additional telephone equipment such as a Call Display box or cordless telephone line jack, plug the unit directly into the wall jack.● If you use a DSL/ADSL service, we recommend connecting a DSL/ADSL filter between the base unit and the telephone line jack. Contact your DSL/ADSL provider for details.● The name display service for landline calls may not be available in some areas. Contact your service provider/telephone company for details.● Other telephone equipment may be interfering with this unit. Disconnect the other equipment and try again.
Caller information is displayed or announced late.	<ul style="list-style-type: none">● Depending on your service provider/telephone company, the unit may display or announce the caller's information at the 2nd ring or later.● Move closer to the base unit.
Caller information is not announced.	<ul style="list-style-type: none">● The handset or base unit's ringer volume is turned off. Adjust it (page 31, 33).● When one handset is selected to ring for cellular calls, other units do not announce caller information. To change the selection, see page 17.● The Talking Call Display feature is turned off. Turn it on (page 33).● The ring as cell mode is set to "On (without Talking CID)". To change the mode, see page 17.● The number of rings for the answering system is set to "2 rings" or "Toll saver". Select a different setting (page 50).● Your unit does not announce caller information if<ul style="list-style-type: none">– the base unit or 2 or more handsets are on a call.– a headset is in use.
I cannot dial the phone number edited in the caller list.	<ul style="list-style-type: none">● The phone number you dialed might have been edited incorrectly (for example, the long distance "1" or the area code is missing). Edit the phone number with another pattern (page 42).

Useful Information

Problem	Cause/solution
Time on the unit has shifted.	<ul style="list-style-type: none">● Incorrect time information from incoming Call Display changes the time. Set the time adjustment to "Manual" (off) (page 32).
The 2nd caller's information is not displayed during an outside call. (Visual Call Waiting feature does not function.)	<ul style="list-style-type: none">● In order to use Call Display, Call Waiting, or Visual Call Waiting, you must first contact your service provider/telephone company and subscribe to the desired service. After subscribing, you may need to contact your service provider/telephone company again to activate this specific service, even if you already subscribed to both Call Display and Visual Call Waiting.

Using Bluetooth devices

Problem	Cause/solution
I cannot copy phonebook entries from a cellular phone.	<ul style="list-style-type: none">● Confirm that the cellular phone supports Bluetooth wireless technology.● Confirm that the cellular phone supports the Phone Book Access Profile (PBAP) or Object Push Profile (OPP) specification.● If the cellular phone is already connected to another Bluetooth device such as a Bluetooth headset, turn it off or disconnect it from the cellular phone.● Someone is using a cellular line or headset. Try again later.● Turn the cellular phone off, then turn it on and try again.● If an entry is already stored in the unit's shared phonebook, the entry cannot be copied even by selecting another group.
I cannot have a conversation using the headset.	<ul style="list-style-type: none">● Your Bluetooth headset is not registered. Register it (page 44).● Turn your headset off, then turn it on and try again.
Noise is heard during a call on the headset.	<ul style="list-style-type: none">● A Bluetooth headset can communicate with the base unit within a range of approximately 10 m (33 feet). The connection may be subject to interference from obstructions such as walls or electronic devices. Move closer to the base unit.

Useful Information

Problem	Cause/solution
I cannot connect my headset to the base unit.	<ul style="list-style-type: none">● Confirm that your headset is turned on.● If your headset is already connected to another Bluetooth device such as your cellular phone, disconnect the headset from your cellular phone, then perform the connecting procedure from the base unit.● If someone is using a cellular line, you cannot connect the headset. There can be only one active Bluetooth connection at a time.● The headset has not been registered to the base unit. Register the headset (page 44).
Some headset enhanced features are not available.	<ul style="list-style-type: none">● The base unit does not support enhanced features such as Last number redial or Call reject.
An error tone is heard when I try to program the Bluetooth feature.	<ul style="list-style-type: none">● The bluetooth feature cannot be accessed immediately after connecting the AC adaptor to the base unit. Wait a few seconds and try again.● The headset has not connected to the base unit yet, even though you performed the connecting procedure setting. Wait a few seconds and try again.

Answering system

Problem	Cause/solution
The unit does not record new messages.	<ul style="list-style-type: none">● The answering system is turned off. Turn it on (page 46).● The answering system does not answer or record calls from cellular lines.● The message memory is full. Erase unnecessary messages (page 47).● The recording time is set to "Greeting only". Change the setting (page 50).● If you subscribe to a Voice Mail service, messages are recorded by your service provider/telephone company, not your telephone. Change the unit's number of rings setting or contact your service provider/telephone company (page 50).● The answering system will not answer incoming calls while:<ul style="list-style-type: none">– the base unit or 2 or more handsets are on a cellular call or an intercom call.– a headset is in use.Caller information is recorded in the caller list.

Useful Information

Problem	Cause/solution
I cannot operate the answering system.	<ul style="list-style-type: none"> Someone is using the unit. Wait for the other user to finish. A caller is leaving a message. Wait for the caller to finish. The handset is too far from the base unit. Move closer.
I cannot operate the answering system remotely.	<ul style="list-style-type: none"> The remote access code is not set. Set the remote access code (page 49). You are entering the wrong remote access code. If you have forgotten your remote access code, enter the Remote Access Code setting to check your current code (page 49). Press each key firmly. The answering system is turned off. Turn it on (page 50). You cannot operate the answering system when calling a cellular phone registered to the base unit.

Bluetooth PIN

Problem	Cause/solution
I cannot remember the PIN.	<ul style="list-style-type: none"> Change the PIN using the following method. <ol style="list-style-type: none"> [MENU] # 6 1 9 * 7 0 0 0 Enter the new 4-digit PIN. → [OK] Enter the new 4-digit PIN again. → [SAVE] → [OFF]

Liquid damage

Problem	Cause/solution
Liquid or other form of moisture has entered the handset/base unit.	<ul style="list-style-type: none"> Disconnect the AC adaptor and telephone line cord from the base unit. Remove the batteries from the handset and leave to dry for at least 3 days. After the handset/base unit are completely dry, reconnect the AC adaptor and telephone line cord. Insert the batteries and charge fully before use. If the unit does not work properly, contact an authorized service centre.

Caution:

- To avoid permanent damage, do not use a microwave oven to speed up the drying process.

Useful Information

Industry Canada Notices and other information

NOTICE:

This equipment meets the applicable Industry Canada Terminal Equipment Technical Specifications. This is confirmed by the registration number. The abbreviation, "IC:", before the registration number signifies that registration was performed based on a Declaration of Conformity indicating that Industry Canada technical specifications were met. It does not imply that Industry Canada approved the equipment.

Users should ensure, for their own protection, that the electrical ground connections of the power utility, telephone lines and internal metallic water pipe system, if present, are connected together. This precaution may be particularly important in rural areas.

NOTICE:

The **Ringer Equivalence Number (REN)** assigned to each terminal device provides an indication of the maximum number of terminals allowed to be connected to a telephone interface. The termination on an interface may consist of any combination of devices subject only to the requirement that the sum of the Ringer Equivalence Numbers of all the devices does not exceed 5.

The Ringer Equivalence Number (REN) of this unit: (found on the bottom of the unit).

NOTICE:

Operation is subject to the following two conditions: (1) this device may not cause interference, and (2) this device must accept any interference, including interference that may cause undesired operation of the device.

Privacy of communications may not be ensured when using this telephone. Some cordless telephones operate at frequencies that may cause interference to nearby TVs and VCRs. To minimize or prevent such interference, the base of the cordless telephone should not be placed near, or on top of, a TV or VCR. If interference is experienced, move the cordless telephone further away from the TV or VCR. This will often reduce, or eliminate, interference.

RF Exposure Warning:

- This product complies with IC radiation exposure limits set forth for an uncontrolled environment.
- To comply with IC RF exposure requirements, the base unit must be installed and operated 20 cm (8 inches) or more between product and all person's body (excluding extremities of hands, wrist and feet).
- This product may not be collocated or operated in conjunction with any other antenna or transmitter.
- For body-worn operation, the handset must be used only with a non-metallic accessory. Use of other accessories may not ensure compliance with IC RF exposure requirements.

Warranty

Panasonic Canada Inc.
5770 Ambler Drive, Mississauga, Ontario L4W 2T3
PANASONIC PRODUCT - LIMITED WARRANTY

EXCHANGE PROGRAM

Panasonic Canada Inc. warrants this product to be free from defects in material and workmanship under normal use and for a period as stated below from the date of original purchase agrees to, at its option either (a) repair your product with new or refurbished parts, (b) replace it with a new or a refurbished equivalent value product, or (c) refund your purchase price. The decision to repair, replace or refund will be made by Panasonic Canada Inc.

Telephone Accessory / Product

One (1) year

This warranty is given only to the original purchaser, or the person for whom it was purchased as a gift, of a Panasonic brand product mentioned above sold by an authorized Panasonic dealer in Canada and purchased and used in Canada, which product was not sold "as is", and which product was delivered to you in new condition in the original packaging.

IN ORDER TO BE ELIGIBLE TO RECEIVE WARRANTY SERVICE HEREUNDER, A PURCHASE RECEIPT OR OTHER PROOF OF DATE OF ORIGINAL PURCHASE, SHOWING AMOUNT PAID AND PLACE OF PURCHASE IS REQUIRED

LIMITATIONS AND EXCLUSIONS

This warranty **ONLY COVERS** failures due to defects in materials or workmanship, and **DOES NOT COVER** normal wear and tear or cosmetic damage. The warranty **ALSO DOES NOT COVER** damages which occurred in shipment, or failures which are caused by products not supplied by Panasonic Canada Inc., or failures which result from accidents, misuse, abuse, neglect, mishandling, misapplication, alteration, faulty installation, set-up adjustments, misadjustment of consumer controls, improper maintenance, improper batteries, power line surge, lightning damage, modification, introduction of sand, humidity or liquids, commercial use such as hotel, office, restaurant, or other business or rental use of the product, or service by anyone other than a Authorized Servicer, or damage that is attributable to acts of God.

Rechargeable batteries are warranted for ninety (90) days from date of original purchase.

THIS EXPRESS, LIMITED WARRANTY IS IN LIEU OF ALL OTHER WARRANTIES, EXPRESS OR IMPLIED, INCLUDING ANY IMPLIED WARRANTIES OF MERCHANTABILITY AND FITNESS FOR A PARTICULAR PURPOSE. IN NO EVENT WILL PANASONIC CANADA INC. BE LIABLE FOR ANY SPECIAL, INDIRECT OR CONSEQUENTIAL DAMAGES RESULTING FROM THE USE OF THIS PRODUCT OR ARISING OUT OF ANY BREACH OF ANY EXPRESS OR IMPLIED WARRANTY. (As examples, this warranty excludes damages for lost time, travel to and from the Authorized Servicer, loss of or damage to media or images, data or other memory or recorded content. This list of items is not exhaustive, but for illustration only.)

In certain instances, some jurisdictions do not allow the exclusion or limitation of incidental or consequential damages, or the exclusion of implied warranties, so the above limitations and exclusions may not be applicable. This warranty gives you specific legal rights and you may have other rights which vary depending on your province or territory.

CONTACT INFORMATION

For product information and operation assistance, please contact:

Our Customer Care Centre: Telephone #: 1-800-561-5505
Fax #: (905) 238-2360
Email link: "Support → contact us → email" on www.panasonic.ca

For defective product exchange within the warranty period, please contact the original dealer or our Customer Care Centre.

Index

Index

- # 3-way conference: 24
- A** Additional handset: 38
 - Alarm: 36
 - Answering calls: 22
 - Answering system
 - Call screening: 46
 - Erasing messages: 47, 48, 49
 - Greeting message: 47
 - Greeting only: 50
 - Listening to messages: 47, 48, 49
 - Number of rings: 50
 - Recording time: 50
 - Remote access code: 49
 - Remote operation: 49
 - Ring count: 50
 - Toll saver: 50
 - Turning on/off: 46, 49, 50
 - Auto talk: 22
- B** Battery: 9, 10
 - Bluetooth wireless technology
 - Cellular phone (Link to cell): 16
 - Headset: 44
 - Phonebook transfer: 43
 - Booster (Clarity booster): 24
- C** C.TWG (Call Waiting Deluxe): 40
 - Call block: 37
 - Call Display service: 39
 - Call share: 24
 - Call Waiting: 23
 - Caller list: 41
 - Caller list edit: 42
 - Cellular calls: 21
 - Cellular phone
 - Deregistration: 20
 - Registration: 16
 - Chain dial: 28
 - CID (Call Display): 41
 - Conference calls: 54
 - Control type: 12
 - Customer support: 34
- D** Date and time: 15
 - Dialing mode: 15
 - Direct command code: 29
- Display
 - Contrast: 33
 - Language: 14
- E** Eco mode: 11
 - Equalizer: 24
 - Error messages: 57
- F** Flash: 23
- G** Groups: 27, 40
- H** Handset
 - Deregistration: 38
 - Locator: 54
 - Name: 37
 - Registration: 38
- Hold: 23
- I** Intercom: 54
- K** Key tone: 33
- L** Landline calls: 21
 - Line mode: 34
 - Link to cell
 - Area code: 19
 - Auto connection: 18
 - Cellular line only mode: 18
 - Cellular line selection: 19
 - Connection: 18
 - Ring as cell mode: 17
 - Select unit to ring: 17
- M** Making calls: 21
 - Missed calls: 39
 - Mute: 23
- N** Night mode: 36
- P** Pause: 22
 - Phonebook: 26
 - PIN: 19
 - Privacy mode: 24
- R** Redialing: 21
 - Ringer ID: 40
 - Ringer tone: 31, 33, 40
 - Rotary/pulse service: 24
- S** SP-PHONE (Speakerphone): 21
- T** Talking Call Display: 39
 - Temporary tone dialing: 24
 - Time adjustment: 32
 - Transferring calls: 54
 - Troubleshooting: 58
- V** Visual Call Waiting: 23



Index

- VM (Voice Mail): 52
- Voice guidance language: 15
- Voice Mail: 50, 52
- Volume
 - Receiver: 21
 - Ringer (Base unit): 22, 31, 33
 - Ringer (Handset): 22, 31, 33
 - Speaker: 21
- W** Wall mounting: 55

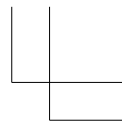
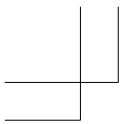

Notes

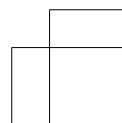
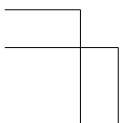
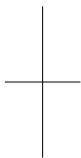

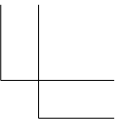
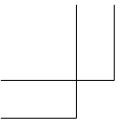

Notes

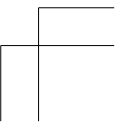
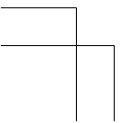

For your future reference

We recommend keeping a record of the following information to assist with any repair under warranty.

Serial No.	Date of purchase
(found on the bottom of the base unit)	
Name and address of dealer	

Attach your purchase receipt here.

Panasonic Canada Inc.

5770 Ambler Drive, Mississauga, Ontario L4W 2T3

© Panasonic System Networks Co., Ltd. 2011

Printed in Malaysia



TG7622C

PNQX3169ZA TT0111MG0