

Owner's Manual Compact Stereo System

Model No. SC-HC39

ENGLISH

ESPAÑOL



Thank you for purchasing this product.
Please read these instructions carefully before using this product,
and save this manual for future use.

If you have any questions, visit:
U.S.A.: www.panasonic.com/support
Canada: www.panasonic.ca/english/support

Register online at www.panasonic.com/register (U.S. customers only)

Included Installation Instructions (→ p. 2 and 18, 19)

The installation work should be done by a qualified installation specialist.

Before commencing work, carefully read these installation instructions and the operating instructions to ensure that installation is performed correctly.

(Please keep these instructions. You may need them when maintaining or moving this unit.)

La referencia rápida en español se puede encontrar en la página 21.

IMPORTANT SAFETY INSTRUCTIONS

Read these operating instructions carefully before using the unit. Follow the safety instructions on the unit and the applicable safety instructions listed below. Keep these operating instructions handy for future reference.

- 1 Read these instructions.
- 2 Keep these instructions.
- 3 Heed all warnings.
- 4 Follow all instructions.
- 5 Do not use this apparatus near water.
- 6 Clean only with dry cloth.
- 7 Do not block any ventilation openings. Install in accordance with the manufacturer's instructions.
- 8 Do not install near any heat sources such as radiators, heat registers, stoves, or other apparatus (including amplifiers) that produce heat.
- 9 Do not defeat the safety purpose of the polarized or grounding-type plug. A polarized plug has two blades with one wider than the other. A grounding-type plug has two blades and a third grounding prong. The wide blade or the third prong are provided for your safety. If the provided plug does not fit into your outlet, consult an electrician for replacement of the obsolete outlet.
- 10 Protect the power cord from being walked on or pinched particularly at plugs, convenience receptacles, and the point where they exit from the apparatus.
- 11 Only use attachments/accessories specified by the manufacturer.
- 12 Use only with the cart, stand, tripod, bracket, or table specified by the manufacturer, or sold with the apparatus. When a cart is used, use caution when moving the cart/apparatus combination to avoid injury from tip-over.
- 13 Unplug this apparatus during lightning storms or when unused for long periods of time.
- 14 Refer all servicing to qualified service personnel. Servicing is required when the apparatus has been damaged in any way, such as power-supply cord or plug is damaged, liquid has been spilled or objects have fallen into the apparatus, the apparatus has been exposed to rain or moisture, does not operate normally, or has been dropped.



WARNING

Unit

- To reduce the risk of fire, electric shock or product damage,
 - Do not expose this unit to rain, moisture, dripping or splashing.
 - Do not place objects filled with liquids, such as vases, on this unit.
 - Use only the recommended accessories.
 - Do not remove covers.
 - Do not repair this unit by yourself. Refer servicing to qualified service personnel.

AC power supply cord

- The power plug is the disconnecting device. Install this unit so that the power plug can be unplugged from the socket outlet immediately.

CAUTION

Unit

- This unit utilizes a laser. Use of controls or adjustments or performance of procedures other than those specified herein may result in hazardous radiation exposure.
- Do not place sources of naked flames, such as lighted candles, on this unit.

Placement

- To reduce the risk of fire, electric shock or product damage,
 - Do not install or place this unit in a bookcase, built-in cabinet or in another confined space. Ensure this unit is well ventilated.
 - Do not obstruct this unit's ventilation openings with newspapers, tablecloths, curtains, and similar items.

Battery

- Danger of explosion if battery is incorrectly replaced. Replace only with the type recommended by the manufacturer.
- Mishandling of batteries can cause electrolyte leakage and may cause a fire.
 - Remove the battery if you do not intend to use the remote control for a long period of time. Store in a cool, dark place.
 - Do not heat or expose to flame.
 - Do not leave the battery(ies) in a car exposed to direct sunlight for a long period of time with doors and windows closed.
 - Do not take apart or short circuit.
 - Do not recharge alkaline or manganese batteries.
 - Do not use batteries if the covering has been peeled off.
- When disposing of the batteries, please contact your local authorities or dealer and ask for the correct method of disposal.





CAUTION

**RISK OF ELECTRIC SHOCK
DO NOT OPEN**



CAUTION : TO REDUCE THE RISK OF ELECTRIC SHOCK, DO NOT REMOVE SCREWS. NO USER-SERVICEABLE PARTS INSIDE. REFER SERVICING TO QUALIFIED SERVICE PERSONNEL.

 The lightning flash with arrowhead symbol, within an equilateral triangle, is intended to alert the user to the presence of uninsulated "dangerous voltage" within the product's enclosure that may be of sufficient magnitude to constitute a risk of electric shock to persons.

 The exclamation point within an equilateral triangle is intended to alert the user to the presence of important operating and maintenance (servicing) instructions in the literature accompanying the appliance.

Product Identification Marking is located on the bottom of the unit.

Conforms to UL STD 60065.
Certified to CAN/CSA STD C22.2 No.60065.

-If you see this symbol-

Information on Disposal in other Countries outside the European Union



This symbol is only valid in the European Union.

If you wish to discard this product, please contact your local authorities or dealer and ask for the correct method of disposal.

Except for Canada

CAUTION - VISIBLE AND INVISIBLE LASER RADIATION WHEN OPEN AND INTERLOCK DEFEATED. DO NOT STARE INTO BEAM.
FDA 21CFR / CLASS II (IIa) RQLS0475

(Inside of product)

THE FOLLOWING APPLIES IN THE U.S.A. AND CANADA

This transmitter must not be co-located or operated in conjunction with any other antenna or transmitter.

This equipment complies with FCC/IC radiation exposure limits set forth for an uncontrolled environment and meets the FCC radio frequency (RF) Exposure Guidelines in Supplement C to OET65 and RSS-102 of the IC radio frequency (RF) Exposure rules. This equipment has very low levels of RF energy that is deemed to comply without maximum permissive exposure evaluation (MPE). But it is desirable that it should be installed and operated keeping the radiator at least 20 cm (7 7/8") or more away from person's body (excluding extremities: hands, wrists, feet and ankles).

THE FOLLOWING APPLIES ONLY IN THE U.S.A.

FCC Note:

This equipment has been tested and found to comply with the limits for a Class B digital device, pursuant to Part 15 of the FCC Rules.

These limits are designed to provide reasonable protection against harmful interference in a residential installation. This equipment generates, uses and can radiate radio frequency energy and, if not installed and used in accordance with the instructions, may cause harmful interference to radio communications.

However, there is no guarantee that interference will not occur in a particular installation. If this equipment does cause harmful interference to radio or television reception, which can be determined by turning the equipment off and on, the user is encouraged to try to correct the interference by one or more of the following measures:

- Reorient or relocate the receiving antenna.
- Increase the separation between the equipment and receiver.
- Connect the equipment into an outlet on a circuit different from that to which the receiver is connected.
- Consult the dealer or an experienced radio/TV technician for help.

Any unauthorized changes or modifications to this equipment would void the user's authority to operate this device.

This device complies with Part 15 of the FCC Rules. Operation is subject to the following two conditions:

- (1) This device may not cause harmful interference, and
- (2) this device must accept any interference received, including interference that may cause undesired operation.

Responsible Party:
Panasonic Corporation of North America
Two Riverfront Plaza, Newark, NJ 07102-5490
Support Contact: <http://www.panasonic.com/contactinfo>

THE FOLLOWING APPLIES ONLY IN CANADA

This device complies with RSS-210 of the IC Rules. Operation is subject to the following two conditions:

- (1) This device may not cause harmful interference,
- (2) This device must accept any interference received, including interference that may cause undesired operation of this device.

THE FOLLOWING APPLIES ONLY IN CANADA

CAN ICES-3(B)/NMB-3(B)

Table of contents

IMPORTANT SAFETY INSTRUCTIONS	2
Accessories	4
Control reference guide	5
Connections	6
Inserting media	7
Bluetooth® operations	8
Media playback controls	10
Listening to the radio	11
Sound adjustment	12
Clock and Timer	12
Others	13
Troubleshooting	14
Licenses	16
Playable media	16
Unit and media care	16
About Bluetooth®	17
Attaching the unit to a wall (optional)	18
Specifications	20
Spanish Quick Reference / Referencia rápida en español	21
Limited Warranty (ONLY FOR U.S.A.)	22
Limited Warranty (ONLY FOR CANADA)	23

About descriptions in this Owner's Manual

- Pages to be referred to are indicated as “→ p. ○○”.
- Unless otherwise indicated, operations are described using the remote control.

Accessories

Check the supplied accessories before using this unit.

- | | |
|--|--|
| <input type="checkbox"/> 1 Remote control
(N2QAYB000949) | <input type="checkbox"/> 1 FM indoor antenna
(RSAX0002) |
| <input type="checkbox"/> 1 Battery for remote control |  |
| <input type="checkbox"/> 1 AC power supply cord
(K2CB2CB00022) | |

Wall mounting accessories

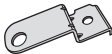
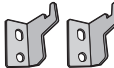
- | | |
|---|--|
| <input type="checkbox"/> 1 Safety holder
(RSC1266) | <input type="checkbox"/> 2 Wall mount brackets
(RSC1262) |
|  |  |
| <input type="checkbox"/> 1 Screw
(XTB3+8JFJK) | |

(ONLY FOR CANADA)

The enclosed Canadian French label sheet corresponds to the English display on the top of the unit.



- Do not use AC power supply cord with other equipment.
- Product numbers provided in this Owner's Manual are correct as of November 2013. These may be subject to change.

Control reference guide

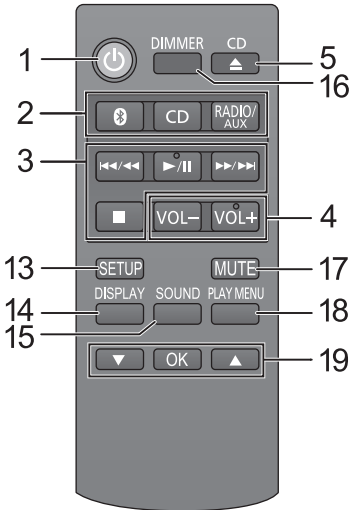
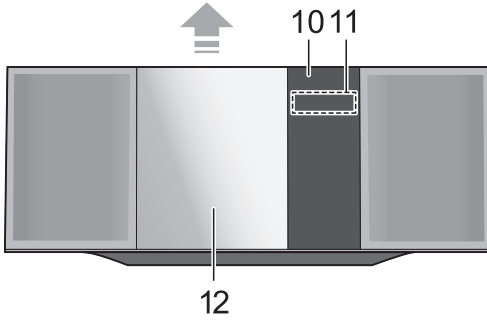
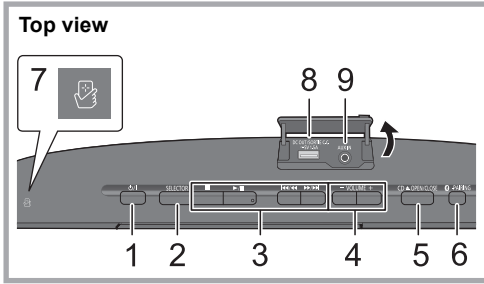

- 1 Standby/on switch [⏻/⏻] (⏻)
Press to switch the unit from on to standby mode or vice versa.
In standby mode, the unit is still consuming a small amount of power.
- 2 Select the audio source
On this unit:
“CD” → “BLUETOOTH” → “FM” → “AUX”
On the remote control
[Bluetooth]: “BLUETOOTH”
[CD]: “CD”
[RADIO/AUX]: “FM” ↔ “AUX”
- 3 Basic playback control buttons
- 4 Adjust the volume (0 (min) to 50 (max))
- 5 Open or close the sliding door
- 6 Bluetooth®-pairing button
 - Press to select “BLUETOOTH” as the audio source.
 - Press and hold to enter pairing mode (→ p. 8) or disconnect a Bluetooth® device (→ p. 9).
- 7 NFC touch area (→ p. 8)
- 8 DC OUT terminal (→ p. 7)
- 9 AUX IN jack (→ p. 6)
- 10 Remote control signal sensor
Distance: Within approx. 7 m (23 ft) directly in front
Angle: Approx. 30° left and right
- 11 Display
- 12 Sliding door
- 13 Enter setup menu
- 14 Change the displayed information
- 15 Enter sound menu
- 16 Dim the display panel
Press again to cancel.
- 17 Mute the sound
Press again to cancel. “MUTE” is also canceled when the volume is adjusted or the unit is turned off.
- 18 Enter playback menu
- 19 Selection/OK

Using the remote control

Insert the battery so the terminals (+ and -) match those in the remote control.

Point it at the remote control signal sensor on this unit.

- To avoid interference, please do not put any objects in front of signal sensor.

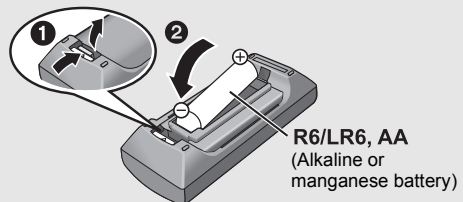

Connections

1 Connect the antenna.

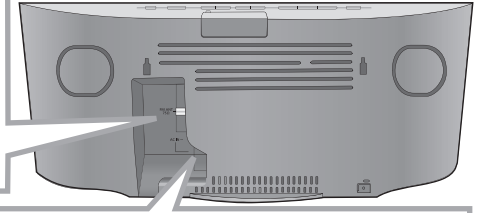
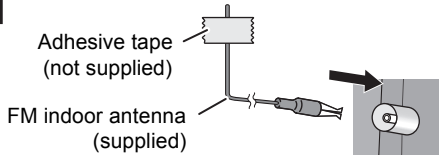

2 Connect the AC power supply cord after all other connections are completed.

This unit consumes a small amount of AC power (→ p. 20) even when turned off.

- In the interest of energy conservation, if you will not be using this unit for an extended period of time, unplug it from the AC outlet.

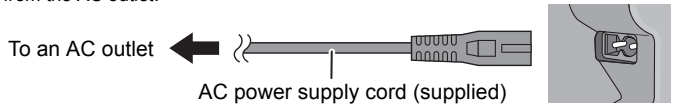

- These speakers do not have magnetic shielding. Do not place them near a TV, personal computer or other magnetic devices.
- Tape the antenna to a wall or column in a position with the least amount of interference.
- To improve FM radio reception in low signal areas, an external antenna (not supplied) can be connected using a “right angle Quick Disconnect “F” type connector” (not supplied).

Connect an external music device

- 1 Connect an external music device using an audio cable (not supplied).

- Plug type: $\varnothing 3.5$ mm ($1/8$ ”) stereo

- 2 Press [RADIO/AUX] to select “AUX” and start playback on the connected device.

■ To select the sound input level of the external device

- 1 While in AUX mode, press [SOUND] repeatedly to select “INPUT LEVEL”.

- 2 Press [▲, ▼] to select “NORMAL” or “HIGH” and then press [OK].

- The factory default is “NORMAL”.

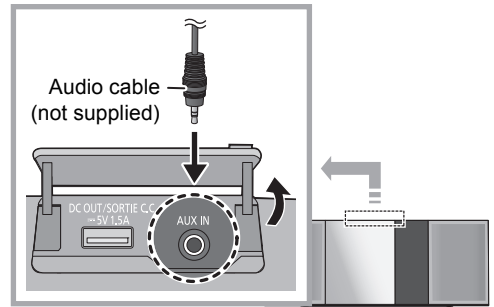

- To improve sound distortion when “HIGH” is selected, select “NORMAL”.
- Switch the equalizer off or turn the volume of the external device down to reduce the input signal. High level of input signal will distort the sound.
- For details, refer to the owner’s manual of the device.

Inserting media

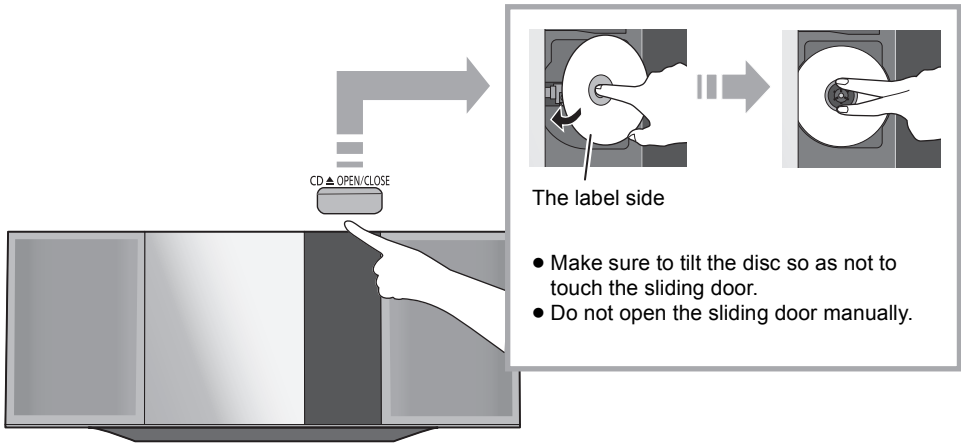

Charging a device

Charging starts when a device (rated value: 5 V/1.5 A) is connected to the DC OUT terminal of this unit. Note that the port cannot be used for purposes other than supplying/charging power.

1 Turn the unit on.

2 Connect a device.

↳ Confirm from the screen of the connected device, etc. to make sure charging has started.

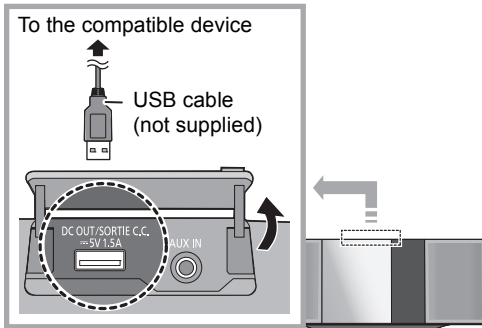

- A cable compatible with your device is required. Use the cable that comes with your device.
- Even if you connect a cable compatible with the DC OUT terminal of this unit, your device may not be charged. In that case, use the charger that comes with the device.
- Depending on your device, using other chargers may not work. Check the owner's manual of your device before use.
- Do not connect a device with a rated value higher than 5 V/1.5 A to this unit.
- To check if charging is complete, look at the screen of the connected device, etc.
- Once fully charged, remove the USB cable from the DC OUT terminal.
- To continue charging during standby mode, make sure the device has started charging before turning the unit to standby mode.
 - When charging a depleted device, do not turn the unit to standby mode until the device becomes operational.



- Make sure that the unit does not fall when inserting or removing media.
- When moving this unit, be sure to remove all media and turn this unit to standby mode.

Bluetooth® operations

You can listen to the sound from the Bluetooth® audio device from this unit wirelessly.

- Refer to the owner's manual of the Bluetooth® device for details.
- If you intend to use an NFC (Near Field Communication)-compatible Bluetooth® device, proceed to "One-Touch Connection (Connecting by NFC)".

Connecting via Bluetooth® menu

Preparation

- Turn on the Bluetooth® feature of the device and place the device near this unit.

■ Pairing with Bluetooth® devices

- 1 Press [**B**] to select "BLUETOOTH".
↳ If "PAIRING" is indicated on the display, go to step 4.

To enter pairing mode*

- 2 Press [PLAY MENU] to select "PAIRING".
- 3 Press [**▲**, **▼**] to select "OK? YES" and then press [OK].

To pair with a device

- 4 Select "SC-HC39" from the Bluetooth® device's Bluetooth® menu.
↳ The name of the connected device is indicated on the display for a few seconds.
- 5 Start playback on the Bluetooth® device.

* You can also enter pairing mode by pressing and holding [**B** -PAIRING] on the unit.

■ Connecting a paired Bluetooth® device

- 1 Press [**B**] to select "BLUETOOTH".
↳ "READY" is indicated on the display.
- 2 Select "SC-HC39" from the Bluetooth® device's Bluetooth® menu.
↳ The name of the connected device is indicated on the display for a few seconds.
- 3 Start playback on the Bluetooth® device.



- If prompted for the passkey, input "0000".
- You can register up to 8 devices with this unit. If a 9th device is paired, the device that has not been used the longest will be replaced.
- This unit can only be connected to one device at a time.
- When "BLUETOOTH" is selected as the source, this unit will automatically try and connect to the last connected Bluetooth® device.

One-Touch Connection (Connecting by NFC)

For NFC-compatible Bluetooth® devices (Android™ devices) only

Simply by touching an NFC (Near Field Communication)-compatible Bluetooth® device on the unit, you can complete all preparations, from registering a Bluetooth® device to establishing a connection.

Preparation

- Turn on the NFC feature of the device.
- An Android device lower than version 4.1 requires the installation of the App "Panasonic Music Streaming" (free of charge).
 - 1 Enter "Panasonic Music Streaming" in the search box of Google Play™ to search, and then select "Panasonic Music Streaming".
 - 2 Start the App "Panasonic Music Streaming" on the device.
 - Follow on-screen instructions on your device.
 - Always use the latest version of the App.

- 1 Press [**B**] to select "BLUETOOTH".
- 2 Touch and hold your device on the NFC touch area of this unit [**B**]. (→ p. 5)

Do not move the Bluetooth® device until it beeps, displays a message or reacts in some way. Once the Bluetooth® device has reacted, move the device away from this unit.

- When the registration and connection of the Bluetooth® device is complete, the name of the connected device is indicated on the display for a few seconds.
 - The location of the NFC touch area differs depending on the device. When a connection cannot be established even if your Bluetooth® device has touched the NFC touch area of this unit, change the position of the device. The condition may also improve if you download the dedicated App "Panasonic Music Streaming" and start it up.
- 3 Start playback on the Bluetooth® device.



- If you touch another device to this unit, you can update the Bluetooth® connection. The previously connected device will be disconnected automatically.
- When the connection is established, playback may start automatically depending on the type of device being used.
- The One-Touch Connection may not work properly depending on the type of device being used.

Bluetooth® transmission mode

You can change the transmission mode to prioritize transmission quality or sound quality.

Preparation

- Press [**B**] to select "BLUETOOTH".
- If a Bluetooth® device is already connected, disconnect it.

- 1 Press [PLAY MENU] repeatedly to select "LINK MODE".
- 2 Press [**▲**, **▼**] to select the mode and then press [OK].

MODE 1: Emphasis on connectivity

MODE 2: Emphasis on sound quality



- Select "MODE 1" if the sound is interrupted.
- The factory default is "MODE 2".

Bluetooth® input level

If the sound input level from the Bluetooth® device is too low, change the input level setting.

Preparation

- Connect a Bluetooth® device.

- 1 Press [PLAY MENU] repeatedly to select "INPUT LEVEL".
- 2 Press [**▲**, **▼**] to select the level and then press [OK].

"LEVEL 0" ↔ "LEVEL + 1" ↔ "LEVEL + 2"

↑—————↑



- Select "LEVEL 0" if the sound is distorted.
- The factory default is "LEVEL 0".

Disconnecting a Bluetooth® device

- 1 While a Bluetooth® device is connected:
Press [PLAY MENU] repeatedly to select "DISCONNECT?".
- 2 Press [**▲**, **▼**] to select "OK? YES" and then press [OK].



- You can also disconnect the Bluetooth® device by pressing and holding [**B** -PAIRING] on the unit.
- The Bluetooth® device will be disconnected if a different audio source (e.g., "CD") is selected.

Media playback controls

The following marks indicate the availability of the feature.

CD : CD audio in CD-DA format

Bluetooth : Connected Bluetooth® device

Preparation

- Turn the unit on.
- Insert a disc or connect the Bluetooth® device.
- Press [CD] or [Bluetooth] to select the audio source.

Basic controls (CD, Bluetooth)

Play	Press [▶/].
Stop	Press [■].
Pause	Press [▶/]. Press again to restart play.
Skip	Press [◀◀/▶▶] or [▶▶/▶▶] to skip track.
Search	During play or pause, press and hold [◀◀/▶▶] or [▶▶/▶▶].

To display information

Press [DISPLAY] repeatedly.



- To use this unit's remote control with a Bluetooth® device, the Bluetooth® device must support AVRCP (Audio Video Remote Control Profile). Depending on the status of the device, some controls may not work.

Playback modes (CD)

Select the playback mode.

- 1 Press [PLAY MENU] to select "PLAYMODE" or "REPEAT".
- 2 Press [▲, ▼] to select the setting and then press [OK].

PLAYMODE

OFF PLAYMODE	Cancels the play mode setting.
1-TRACK	Only plays the selected track. <ul style="list-style-type: none">• "1", "♪" is displayed. (Skip to the desired track)
RANDOM	Plays the contents randomly. <ul style="list-style-type: none">• "RND" is displayed.

REPEAT

ON REPEAT	Turns on repeat mode. <ul style="list-style-type: none">• "↺" is displayed.
OFF REPEAT	Turns off repeat mode.



- During random play, you cannot skip to the previous track.
- The mode is canceled when you open the sliding door.

Listening to the radio

You can preset up to 30 channels.

Preparation

- Make sure that the FM antenna is connected. (→ p. 6)
- Turn the unit on.
- Press [RADIO/AUX] to select "FM".



- A station previously stored is overwritten when another station is stored in the same channel preset.

Presetting stations automatically

- 1 Press [PLAY MENU] to select "A.PRESET".
- 2 Press [▲, ▼] to select "LOWEST" or "CURRENT" and then press [OK].

LOWEST:

To begin auto preset with the lowest frequency (FM 87.9 or FM 87.5).

CURRENT:

To begin auto preset with the current frequency.*

↳ The tuner starts to preset all the stations it can receive into the channels in ascending order.

* To change the frequency, refer to "Manual tuning and presetting".

Listening to a preset channel

- 1 Press [PLAY MENU] repeatedly to select "TUNEMODE".
- 2 Press [▲, ▼] to select "PRESET" and then press [OK].
- 3 Press [◀◀/◀◀] or [▶▶/▶▶] to select the channel.

Manual tuning and presetting

Select a radio broadcast.

- 1 Press [PLAY MENU] repeatedly to select "TUNEMODE".
- 2 Press [▲, ▼] to select "MANUAL" and then press [OK].
- 3 Press [◀◀/◀◀] or [▶▶/▶▶] to tune to the required station.
 - To start automatic tuning, press and hold [◀◀/◀◀] or [▶▶/▶▶] until the frequency starts scrolling. Tuning stops when a station is found.

To preset the channel

- 4 While listening to the radio broadcast, press [OK].
- 5 Press [▲, ▼] to select the channel and then press [OK].

To improve FM sound quality

- 1 While receiving FM broadcasts, press [PLAY MENU] repeatedly to select "FM MODE".
- 2 Press [▲, ▼] to select "MONO" and then press [OK].
 - This setting can be preset and memorized. To do so, continue to step 4 of "Manual tuning and presetting".



- Select "STEREO" in step 2 to return to stereo broadcasts.
- "MONO" is canceled if the frequency is changed.

To display the current signal status

Press [DISPLAY].

"FM ST": The FM signal is tuned and in stereo.

"FM": There is no tuned signal or the FM signal is in monaural.

"FM MONO": "MONO" is selected in step 2 of "To improve FM sound quality" (→ above).



- "STEREO" is displayed when this unit tunes to a stereo broadcast.

Others

Auto off function

As a factory default, this unit will turn to standby mode automatically if there is no sound and it is not being used for approximately 20 minutes.

To cancel this function

- 1 Press [SETUP] repeatedly to select "AUTO OFF".
- 2 Press [▲, ▼] to select "OFF" and then press [OK].



- To turn the function on, select "ON" in step 2.
- This setting cannot be selected when "FM" is the source.
- When connected to a Bluetooth® device, the function does not work.

Bluetooth® standby

When "SC-HC39" is selected from a paired Bluetooth® device's Bluetooth® menu, this unit will turn on automatically from standby mode and establish a Bluetooth® connection.

- 1 Press [SETUP] repeatedly to select "BLUETOOTH STANDBY".
- 2 Press [▲, ▼] to select "ON" and then press [OK].



- To turn the function off, select "OFF" in step 2.

Changing the unit and remote control code

When other Panasonic equipment responds to the supplied remote control, change the remote control code.

- 1 Press [CD] to select "CD".
- 2 While pressing and holding [SELECTOR] on the unit, press and hold [CD] on the remote control until the unit's display shows "REMOTE 2".
- 3 Press and hold [OK] and [CD] on the remote control for at least 4 seconds.



- To change the mode back to "REMOTE 1", press [CD] to select "CD" and then repeat the step 2 and 3 but replace [CD] with [Ⓜ].

Software update

Occasionally, Panasonic may release updated software for this unit that may add or improve the way a feature operates. These updates are available free of charge.

For more details, refer to the following website.

<http://panasonic.jp/support/global/cs/>

(This site is in English only.)

Checking the software version

The version of the installed software is displayed.

Press [SETUP] repeatedly to select "SW VER." and then press [OK].

- Press [OK] to exit.

Troubleshooting

Before requesting service, make the following checks. If you are uncertain about some of the check points, or if the solutions indicated in the following guide does not resolve the issue, then refer to “Customer Services Directory (United States)” (→ p. 22) if you reside in the U.S.A. or refer to “Limited Warranty (ONLY FOR CANADA)” (→ p. 23) if you reside in Canada.

To return all settings to the factory defaults

When the following situations occur, reset the memory:

- There is no response when buttons are pressed.
 - You want to clear and reset the memory contents.
- ① Disconnect the AC power supply cord. (Wait for at least 3 minutes before proceeding to step ②.)
 - ② While pressing and holding down [⏻/|] on the unit, reconnect the AC power supply cord.
 - Keep holding down [⏻/|] until “-----” appears on the display.
 - ③ Release [⏻/|].



- All the settings are returned to the factory defaults. You will need to reset the memory items.

General

Humming heard during playback.

- If an AC power supply cord or fluorescent lights are near the cords, then keep other appliances and cords away from the cables.

The unit does not work.

- One of the unit's safety devices may have been activated.
Reset the unit as follows:
 - ① Press [⏻/|] on the unit to switch the unit to standby.
 - If the unit does not switch to standby, press [⏻/|] on the unit for approximately 10 seconds. The unit is forcibly switched to standby. Alternatively, disconnect the AC power supply cord, wait for at least 3 minutes, then reconnect it.
 - ② Press [⏻/|] on the unit to switch it on. If the unit still cannot be operated, consult the dealer.

Charging does not start during standby mode.

- Turn the unit on. Check the charging has started, and then turn the unit to standby mode. (→ p. 7)

Noise is heard.

- When a device is connected to both the AUX IN jack and the DC OUT terminal, noise may be generated depending on the device. In this case, remove the USB cable from the DC OUT terminal.

Disc

Incorrect display or play does not start.

- Make sure that the disc is compatible with this unit. (→ p. 16)
- There is moisture on the lens. Wait for about an hour and then try again.

Bluetooth®

Pairing cannot be completed.

- Check the Bluetooth® device condition.

The device cannot be connected.

- The pairing of the device was unsuccessful or the registration has been replaced. Try re-pairing the device. (→ p. 8)
- This unit might be connected to a different device. Disconnect the other device and try re-pairing the device. (→ p. 8)

The device is connected, but audio cannot be heard through this unit.

- For some built-in Bluetooth® devices, you have to set the audio output to “SC-HC39” manually. Read the owner's manual for the device for details.

The sound is interrupted.

- The device is out of the 10 m (33 ft) communication range. Place the Bluetooth® device closer to this unit.
- Remove any interference between this unit and the device.
- Other devices that use the 2.4 GHz frequency band, such as wireless routers, microwaves, cordless phones, etc. are interfering. Place the Bluetooth® device closer to this unit and distance it from the other devices.
- Select “MODE 1” for stable communication. (→ p. 9)

The One-Touch Connection (NFC feature) is not working.

- Make sure the unit and the NFC feature of the device are turned on. (→ p. 8)

Radio

Static or noisy reception is heard while listening to a radio broadcast.

- Confirm the FM antenna is properly connected. (→ p. 6)
- Adjust the position of the antenna.
- Try to keep a certain amount of distance between the antenna and AC power supply cord.
- Try using an external antenna if there are buildings or mountains nearby. (→ p. 6)
- Turn the TV or other audio players off or separate it from this unit.
- Keep this unit away from cell phones if there is interference.

Stations cannot be selected.

Change the FM frequency step.

- ① Press [RADIO/AUX] to select "FM".
- ② Press and hold [SELECTOR] on the unit.

After a few seconds the display changes to show the current lowest frequency. Continue to hold the button down. The lowest frequency changes and the step is changed.

Remote control

The remote control does not work properly.

- The battery is depleted or inserted incorrectly. (→ p. 5)

Messages

The following messages or service numbers may appear on the unit's display.

"--:--"

- You plugged the AC power supply cord in for the first time or there was a power failure recently. Set the time (→ p. 12).

"ADJUST CLOCK"

- Clock is not set. Adjust the clock accordingly.

"ADJUST TIMER"

- Play timer is not set. Adjust the play timer accordingly.

"AUTO OFF"

- The unit has been left unused for about 20 minutes and will shut down within a minute. Press any button to cancel it.

"DIMMER"

- Appears 10 seconds after the volume is turned to "0".

"ERROR"

- Incorrect operation is performed. Read the instructions and try again.

"F □□" ("□" stands for a number.)

- There is a problem with this unit. Write down the displayed number, disconnect the AC power supply cord and consult your dealer.

"ILLEGAL OPEN"

- Sliding door is in the wrong position. Turn the unit off and on again. If this display appears again, consult the dealer.

"NO DISC"

- Insert a disc to be played. (→ p. 7)

"NO PLAY"

- A CD that is not in CD-DA format is inserted. It cannot be played.
- The unit may have a problem. Turn the unit off and then on again.

"READING"

- The unit is checking the CD information. After this display has disappeared, start operating.

"REMOTE □" ("□" stands for a number.)

- The remote control and this unit are using different codes. Change the code on the remote control.
 - When "REMOTE 1" is displayed, press and hold [OK] and [8] for at least 4 seconds.
 - When "REMOTE 2" is displayed, press and hold [OK] and [CD] for at least 4 seconds.

Licenses

Google Play and Android are trademarks of Google Inc.

The Bluetooth® word mark and logos are owned by the Bluetooth SIG, Inc. and any use of such marks by Panasonic Corporation is under license. Other trademarks and trade names are those of their respective owners.

Playable media

Compatible CD

- A disc with the CD Logo.



- This unit can play back discs that conform to the CD-DA format.
- The unit may not be able to play some discs due to the condition of the recording.
- This unit cannot play back MP3 files.
- Before playback, finalize the disc on the device it was recorded on.

Note about using a DualDisc

- The digital audio content side of a DualDisc does not meet the technical specifications of the Compact Disc Digital Audio (CD-DA) format so play may not be possible.
- Do not use a DualDisc in this unit as it may not be possible to insert it correctly and it may get scratched.

Unit and media care

Pull out the AC power plug from the outlet before maintenance.

■ Clean this unit with a soft, dry cloth

- When dirt is heavy, wring a wet cloth tightly to wipe the dirt, and then wipe it with a dry cloth.
- When cleaning the speaker covers, use a fine cloth. Do not use tissues or other materials that can fall apart. Small pieces may get stuck inside the speaker cover.
- Never use alcohol, paint thinner or benzine to clean this unit.
- Before using chemically treated cloth, carefully read the cloth's instructions.

■ Maintenance of the lens

- Clean the lens regularly to prevent malfunctions. Use a dust blower to remove dust and a cotton swab if it is extremely dirty.
- You cannot use a CD type lens cleaner.
- Do not leave the sliding door open for prolonged periods of time. This will cause the lens to get dirty.
- Be careful not to touch the lens with your fingers.

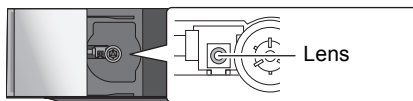

■ Clean discs

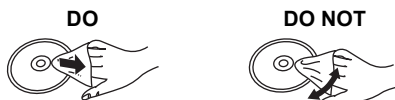

Wipe with a damp cloth and then wipe dry.

■ Disc handling precautions

- Handle discs by the edges to avoid inadvertent scratches or fingerprints on the disc.
- Do not attach labels or stickers to discs.
- Do not use record cleaning sprays, benzine, thinner, static electricity prevention liquids or any other solvent.
- Do not use the following discs:
 - Discs with exposed adhesive from removed stickers or labels (rented discs etc.).
 - Discs that are badly warped or cracked.
 - Irregularly shaped discs, such as heart shapes.

■ To dispose or transfer this unit

The unit may keep the user settings information in the unit. If you discard this unit either by disposal or transfer, then follow the procedure to return all the settings to the factory defaults to delete the user settings.

- (→ p. 14, "To return all settings to the factory defaults")
- The operation history may be recorded in the memory of this unit.

About Bluetooth®

Panasonic bears no responsibility for data and/or information that is compromised during a wireless transmission.

■ Frequency band used

- This system uses the 2.4 GHz frequency band.

■ Certification of this device

- This system conforms to frequency restrictions and has received certification based on frequency laws. Thus, a wireless permit is not necessary.
- The actions below are punishable by law in some countries:
 - Taking apart or modifying the system.
 - Removing specification indications.

■ Restrictions of use

- Wireless transmission and/or usage with all Bluetooth® equipped devices is not guaranteed.
- All devices must conform to standards set by Bluetooth SIG, Inc.
- Depending on the specifications and settings of a device, it can fail to connect or some operations can be different.
- This system supports Bluetooth® security features. But depending on the operating environment and/or settings, this security is possibly not sufficient. Transmit data wirelessly to this system with caution.
- This system cannot transmit data to a Bluetooth® device.

■ Range of use

- Use this device at a maximum range of 10 m (33 ft). The range can decrease depending on the environment, obstacles or interference.

■ Interference from other devices

- This system may not function properly and troubles such as noise and sound jumps may arise due to radio wave interference if this system is located too close to other Bluetooth® devices or the devices that use the 2.4 GHz band.
- This system may not function properly if radio waves from a nearby broadcasting station, etc. is too strong.

■ Intended usage

- This system is for normal, general use only.
- Do not use this system near an equipment or in an environment that is sensitive to radio frequency interference (example: airports, hospitals, laboratories, etc).

Attaching the unit to a wall (optional)

This unit can be wall mounted using the supplied wall mount brackets, etc. Make sure that the wall and the screws used for securing to the wall are capable of supporting at least 33 kg (72.8 lbs). The screws and other items are not supplied as the type and size will vary with each installation.

- Refer to step 5 of “Wall mount instructions” for details about the required screws.
- As an additional protective measure, attach the unit to the wall with the fall prevention cord.

Installation accessories

■ Supplied accessories

- 1 Safety holder
- 1 Screw
- 2 Wall mount brackets

■ Additionally required accessories (commercially available)

- 4 Wall mount bracket fixing screws
- 1 Safety holder fixing screw
- 1 Fall prevention cord*
- 1 Screw eye

* Use a cord that is capable of supporting over 33 kg (72.8 lbs) (with a diameter of about 1.5 mm (1/16")).

- Keep the safety holder out of reach of children to prevent swallowing.
- Keep the screws out of reach of children to prevent swallowing.
- Keep the wall mount brackets out of reach of children to prevent swallowing.

Safety precautions

Professional installation is required.
The installation should never be done by any other than a qualified installation specialist.
PANASONIC DISCLAIMS ANY PROPERTY DAMAGE AND/OR SERIOUS INJURY, INCLUDING DEATH RESULTING FROM IMPROPER INSTALLATION OR INCORRECT HANDLING.

WARNING:

To prevent injury, this apparatus must be securely attached to the wall in accordance with the installation instructions.

Wall mount instructions

Before installation, turn the unit off and disconnect the AC power supply cord from the AC outlet.

1 Detach the stand from the unit.

- Unscrew the fixing screw at the bottom of the unit.
- Gently pull the stand off the unit as illustrated.
- Keep the removed screw and the stand in a safe place.

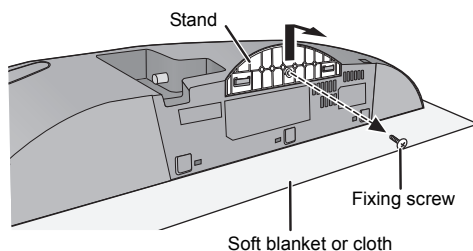

2 Fix the safety holder onto the unit with the screw (supplied).

- Screw tightening torque: 50 N•cm (0.4 lbf•ft) to 70 N•cm (0.5 lbf•ft).

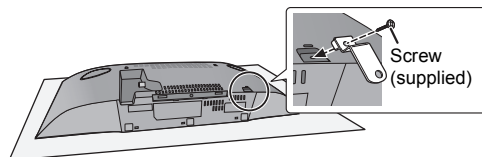

3 Attach the fall prevention cord (not supplied) to this unit.

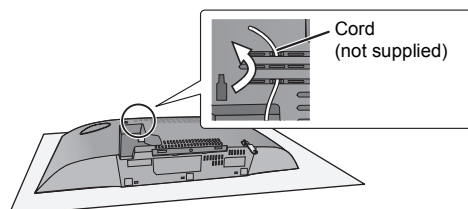

4 Measure and mark the position of both sides of the wall mount brackets.

- Use figures below to identify the screwing positions.

The position to attach the wall mount brackets

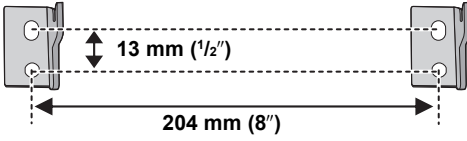

Space required

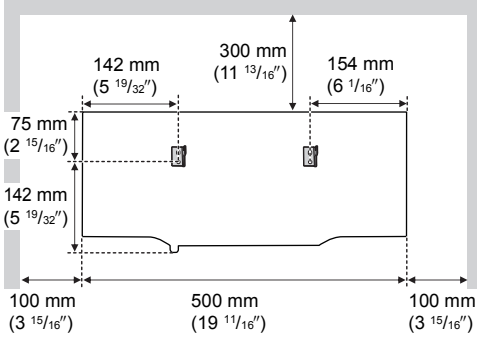

5 Attach the wall mount bracket to both sides of the wall with two screws (not supplied).

- Use a level to ensure both wall mount brackets are level.

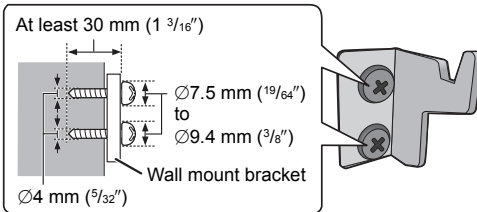

6 Hook the unit securely onto the wall mount brackets with both hands.

- Connect the FM antenna and the AC power supply cord to the unit before hanging the unit onto the wall. (→ p. 6)
- After hanging the unit, release your hands carefully to confirm the unit sits securely on the wall mount brackets.

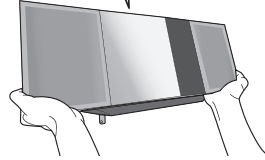
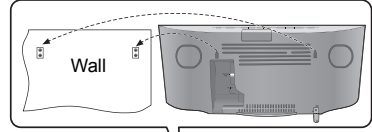

7 Drive the safety holder fixing screw (not supplied) to secure the safety holder onto the wall.

- Refer to step 5 for requirements before screwing.

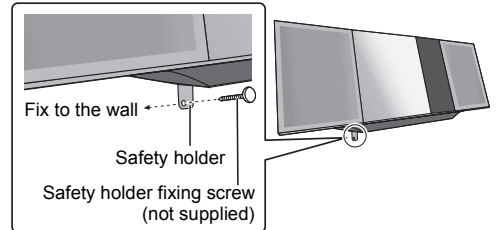

8 Attach the fall prevention cord (not supplied) to the wall.

- Make sure that the slack of the cord is minimal.

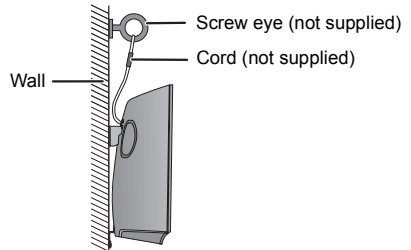

Specifications

■ GENERAL

Power consumption	26 W
Power consumption in standby mode*1, 2	Approx. 0.1 W
(When "BLUETOOTH STANDBY" is "ON")*2	Approx. 0.2 W
Power supply	AC 120 V, 60 Hz

Dimensions (W×H×D)

500 mm×205 mm×92 mm
(19 1/16"×8 1/16"×3 5/8")

Mass (Weight)

Approx. 2.5 kg (5.5 lbs)

Operating temperature range

0 °C to +40 °C (+32 °F to +104 °F)

Operating humidity range

35 % to 80 % RH (no condensation)

■ AMPLIFIER SECTION

Output power:

RMS Output Power Stereo mode

Front Ch (both ch driven)

20 W per channel (8 Ω),
1 kHz, 10 % THD

Total RMS Stereo mode power 40 W

FTC Output Power Stereo mode

Front Ch (both ch driven)

15 W per channel (8 Ω),
20 Hz to 20 kHz, 1 % THD

Total FTC Stereo mode power 30 W

■ TUNER SECTION

Preset Memory

FM 30 stations

Frequency Modulation (FM)

Frequency range

87.9 MHz to 107.9 MHz (200 kHz step)
87.5 MHz to 108.0 MHz (100 kHz step)

Antenna terminals 75 Ω (unbalanced)

■ DISC SECTION

Disc played [8 cm (3") or 12 cm (5")]

CD, CD-R/RW (CD-DA)

Pick up

Wavelength 790 nm (CD)

■ SPEAKER SYSTEM SECTION

Speaker unit(s)

Full range

6.5 cm (2 1/2") Cone type×1 per channel

Passive Radiator

8 cm (3 1/8")×2 per channel

Impedance

8 Ω

■ TERMINAL SECTION

DC OUT (USB A type)

5 V 1.5 A

AUX IN

Stereo, 3.5 mm (1/8") jack

■ BLUETOOTH SECTION

Version

Bluetooth® Ver.2.1+EDR

Class

Class 2

Supported Profiles

A2DP, AVRCP

Operating Frequency

2.4 GHz band FH-SS

Operation Distance

10 m (33 ft) Line of sight



- Specifications are subject to change without notice.
- Mass and dimensions are approximate.
- Total harmonic distortion is measured by a digital spectrum analyzer.

*1: "BLUETOOTH STANDBY" is "OFF".

*2: No device is connected to the DC OUT terminal before turning to standby mode.

Conexiones

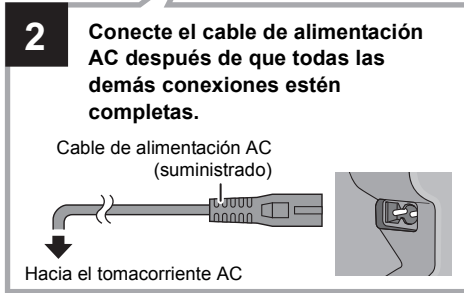
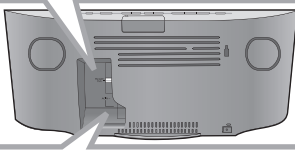
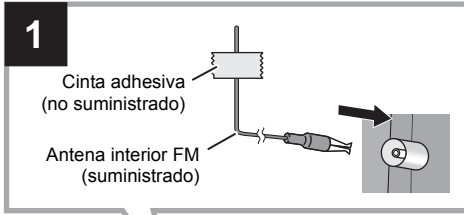

- Consumo de energía en Standby (modo de espera): Aprox. 0,1 W

Operaciones de reproducción de medios

Preparación

- Encienda la unidad.
- Inserte el disco que desea reproducir (→ arriba) o conecte el dispositivo compatible con Bluetooth®.
- Presione [CD] o [Ⓜ] para seleccionar la fuente de audio.

Reproducción básica

Reproducir	Presione [▶/].
Detención	Presione [■].
Pausa	Presione [▶/]. Presione nuevamente para reiniciar la reproducción.
Saltear	Presione [◀◀/▶▶] o [▶▶/▶▶] para saltar una pista.
Búsqueda	Durante la reproducir o pausa Mantenga presionado [◀◀/▶▶] o [▶▶/▶▶].

Insertar un disco

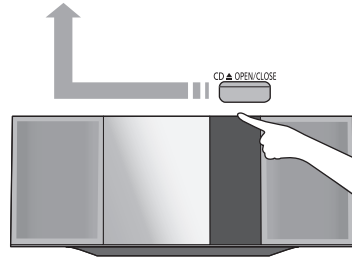
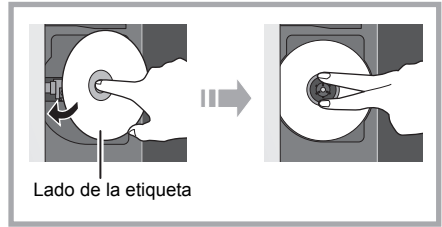

Reloj y temporizador

Ajuste del reloj

Éste es un reloj de 12 horas.

- 1 Presione [SETUP] repetidamente para seleccionar "CLOCK".
- 2 Presione [▲, ▼] para seleccionar la hora y luego presione [OK].

Limited Warranty (ONLY FOR U.S.A.)

Panasonic Products Limited Warranty

Limited Warranty Coverage (For USA Only)

If your product does not work properly because of a defect in materials or workmanship, Panasonic Corporation of North America (referred to as "the warrantor") will, for the length of the period indicated on the chart below, which starts with the date of original purchase ("warranty period"), at its option either (a) repair your product with new or refurbished parts, (b) replace it with a new or a refurbished equivalent value product, or (c) refund your purchase price. The decision to repair, replace or refund will be made by the warrantor.

Product or Part Name	Parts	Labor
Compact Stereo System	1 Year	1 Year
All included Accessories (Except Non-Rechargeable Batteries)	90 Days	Not Applicable
Only Non-Rechargeable Batteries	10 Days	Not Applicable

During the "Labor" warranty period there will be no charge for labor. During the "Parts" warranty period, there will be no charge for parts. This Limited Warranty excludes both parts and labor for non-rechargeable batteries, antennas, and cosmetic parts (cabinet). This warranty only applies to products purchased and serviced in the United States. This warranty is extended only to the original purchaser of a new product which was not sold "as is".

Mail-In Service--Online Repair Request

Online Repair Request

To submit a new repair request and for quick repair status visit our Web Site at www.panasonic.com/repair.

When shipping the unit, carefully pack, include all supplied accessories listed in the Owner's Manual, and send it prepaid, adequately insured and packed well in a carton box. When shipping Lithium Ion batteries please visit our Web Site at www.panasonic.com/BatteryHandling as Panasonic is committed to providing the most up to date information. Include a letter detailing the complaint, a return address and provide a daytime phone number where you can be reached. A valid registered receipt is required under the Limited Warranty.

IF REPAIR IS NEEDED DURING THE WARRANTY PERIOD, THE PURCHASER WILL BE REQUIRED TO FURNISH A SALES RECEIPT/ PROOF OF PURCHASE INDICATING DATE OF PURCHASE, AMOUNT PAID AND PLACE OF PURCHASE. CUSTOMER WILL BE CHARGED FOR THE REPAIR OF ANY UNIT RECEIVED WITHOUT SUCH PROOF OF PURCHASE.

Limited Warranty Limits And Exclusions

This warranty ONLY COVERS failures due to defects in materials or workmanship, and DOES NOT COVER normal wear and tear or cosmetic damage. The warranty ALSO DOES NOT COVER damages which occurred in shipment, or failures which are caused by products not supplied by the warrantor, or failures which result from accidents, misuse, abuse, neglect, mishandling, misapplication, alteration, faulty installation, set-up adjustments, misadjustment of consumer controls, improper maintenance, power line surge, lightning damage, modification, introduction of sand, humidity or liquids, commercial use such as hotel, office, restaurant, or other business or rental use of the product, or service by anyone other than a Factory Service Center or other Authorized Servicer, or damage that is attributable to acts of God.

The model number and serial number of this product can be found on either the back or the bottom of the unit. Please note them in the space provided below and keep for future reference.

MODEL NUMBER SC-HC39 _____
SERIAL NUMBER _____

THESE ARE NO EXPRESS WARRANTIES EXCEPT AS LISTED UNDER "LIMITED WARRANTY COVERAGE".

THE WARRANTOR IS NOT LIABLE FOR INCIDENTAL OR CONSEQUENTIAL DAMAGES RESULTING FROM THE USE OF THIS PRODUCT, OR ARISING OUT OF ANY BREACH OF THIS WARRANTY. (As examples, this excludes damages for lost time, travel to and from the servicer, loss of or damage to media or images, data or other memory or recorded content. The items listed are not exclusive, but for illustration only.) ALL EXPRESS AND IMPLIED WARRANTIES, INCLUDING THE WARRANTY OF MERCHANTABILITY, ARE LIMITED TO THE PERIOD OF THE LIMITED WARRANTY.

Some states do not allow the exclusion or limitation of incidental or consequential damages, or limitations on how long an implied warranty lasts, so the exclusions may not apply to you.

This warranty gives you specific legal rights and you may also have other rights which vary from state to state. If a problem with this product develops during or after the warranty period, you may contact your dealer or Service Center. If the problem is not handled to your satisfaction, then write to the warrantor's Consumer Affairs Department at the addresses listed for the warrantor.

PARTS AND SERVICE, WHICH ARE NOT COVERED BY THIS LIMITED WARRANTY, ARE YOUR RESPONSIBILITY.

Customer Services Directory (United States)

Obtain Product Information and Operating Assistance; locate your nearest Dealer or Service Center; purchase Parts and Accessories; or make Customer Service and Literature requests by visiting our Web Site at:

<http://www.panasonic.com/support>

or, contact us via the web at:

<http://www.panasonic.com/contactinfo>

For hearing or speech impaired TTY users, TTY: 1-877-833-8855

Accessory Purchases (United States)

Purchase Parts, Accessories and Owner's Manual online for all Panasonic Products by visiting our Web Site at:

<http://www.pstc.panasonic.com>

Or, send your request by E-mail to:

npccparts@us.panasonic.com

You may also contact us directly at:

1-800-237-9080 (Fax Only)

(Monday-Friday 9am-9pm EST)

Panasonic National Parts Center

20421 84th Avenue South, Kent, WA 98032

(We accept Visa, MasterCard, Discover Card, American Express)

For hearing or speech impaired TTY users, TTY: 1-866-605-1277

As of April 2014

User memo:

DATE OF PURCHASE _____
DEALER NAME _____
DEALER ADDRESS _____
TELEPHONE NUMBER _____

Limited Warranty (ONLY FOR CANADA)

Panasonic Canada Inc.

5770 Ambler Drive, Mississauga, Ontario L4W 2T3

PANASONIC PRODUCT - LIMITED WARRANTY EXCHANGE PROGRAM

Panasonic Canada Inc. warrants this product to be free from defects in material and workmanship under normal use and for a period as stated below from the date of original purchase agrees to, at its option either (a) repair your product with new or refurbished parts, (b) replace it with a new or a refurbished equivalent value product, or (c) refund your purchase price. The decision to repair, replace or refund will be made by Panasonic Canada Inc.

Panasonic Portable / Clock Radio (without Tape, CD, MD)	One (1) year
Panasonic Audio Product	One (1) year
Panasonic DVD Product	One (1) year
Accessories including rechargeable batteries	Ninety (90) days

This warranty is given only to the original purchaser, or the person for whom it was purchased as a gift, of a Panasonic brand product mentioned above sold by an authorized Panasonic dealer in Canada and purchased and used in Canada, which product was not sold "as is", and which product was delivered to you in new condition in the original packaging.

IN ORDER TO BE ELIGIBLE TO RECEIVE WARRANTY SERVICE HEREUNDER, A PURCHASE RECEIPT OR OTHER PROOF OF DATE OF ORIGINAL PURCHASE, SHOWING AMOUNT PAID AND PLACE OF PURCHASE IS REQUIRED

LIMITATIONS AND EXCLUSIONS

This warranty ONLY COVERS failures due to defects in materials or workmanship, and DOES NOT COVER normal wear and tear or cosmetic damage. The warranty ALSO DOES NOT COVER damages which occurred in shipment, or failures which are caused by products not supplied by Panasonic Canada Inc., or failures which result from accidents, misuse, abuse, neglect, mishandling, misapplication, alteration, faulty installation, set-up adjustments, misadjustment of consumer controls, improper maintenance, power line surge, lightning damage, modification, introduction of sand, humidity or liquids, commercial use such as hotel, office, restaurant, or other business or rental use of the product, or service by anyone other than an Authorized Servicer, or damage that is attributable to acts of God.

Dry cell batteries are also excluded from coverage under this warranty.

THIS EXPRESS, LIMITED WARRANTY IS IN LIEU OF ALL OTHER WARRANTIES, EXPRESS OR IMPLIED, INCLUDING ANY IMPLIED WARRANTIES OF MERCHANTABILITY AND FITNESS FOR A PARTICULAR PURPOSE. IN NO EVENT WILL PANASONIC CANADA INC. BE LIABLE FOR ANY SPECIAL, INDIRECT OR CONSEQUENTIAL DAMAGES RESULTING FROM THE USE OF THIS PRODUCT OR ARISING OUT OF ANY BREACH OF ANY EXPRESS OR IMPLIED WARRANTY. (As examples, this warranty excludes damages for lost time, travel to and from the Authorized Servicer, loss of or damage to media or images, data or other memory or recorded content. This list of items is not exhaustive, but for illustration only.)

In certain instances, some jurisdictions do not allow the exclusion or limitation of incidental or consequential damages, or the exclusion of implied warranties, so the above limitations and exclusions may not be applicable. This warranty gives you specific legal rights and you may have other rights which vary depending on your province or territory.

CONTACT INFORMATION

For product operation and information assistance, please visit our Support page:
www.panasonic.ca/english/support

For defective product exchange within the warranty period, please contact the original dealer.



Panasonic Corporation of North America
Two Riverfront Plaza, Newark, NJ 07102-5490
<http://www.panasonic.com>

Panasonic Canada Inc.
5770 Ambler Drive,
Mississauga, Ontario,
L4W 2T3
www.panasonic.com

