

# Panasonic®

## Operating Instructions

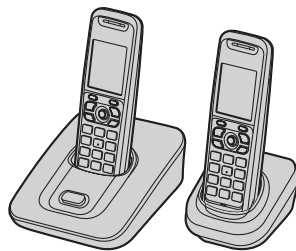

Model shown is KX-TG7412.

DECT  
**6.0**

### Expandable Digital Cordless Phone

Model No. **KX-TG7412C**  
**KX-TG7413C**

### Expandable Digital Cordless Answering System

Model No. **KX-TG7432C**  
**KX-TG7433C**  
**KX-TG7434C**

#### Panasonic's environmental declaration labels

This mark is an environmental label showing that the products are certified as Panasonic's Green Products.



Standby power consumption  
reduced by 59%

[ Standby power consumption 1.1 W  
Compared to the 2005 model KX-TG2431 (2.7 W) ]

### **Thank you for purchasing a Panasonic product.**

This unit is compatible with Call Display. You must subscribe to the appropriate service offered by your service provider/telephone company.

**Charge the batteries for about 7 hours before initial use.**

Please read these operating instructions before using the unit and save them for future reference.

For assistance, please call **1-800-561-5505** or visit us at **www.panasonic.ca**

**Table of Contents**

<b>Introduction</b>		<b>Voice Mail Service</b>	
Model composition . . . . .	3	Voice Mail service . . . . .	39
Accessory information . . . . .	4	<b>Intercom/Locator</b>	
<b>Important Information</b>		Intercom . . . . .	41
For your safety . . . . .	6	Handset locator . . . . .	41
Important safety instructions . . . . .	7	Transferring calls, conference calls . . . . .	41
For best performance . . . . .	7	<b>Useful Information</b>	
Specifications . . . . .	8	Belt clip . . . . .	42
Other information . . . . .	8	Wall mounting . . . . .	42
<b>Getting Started</b>		Error messages . . . . .	43
Setting up . . . . .	9	Troubleshooting . . . . .	44
Note when setting up . . . . .	10	Industry Canada Notices and other information . . . . .	49
Controls . . . . .	11	Warranty . . . . .	50
Display . . . . .	13	<b>Index</b>	
Temporary switch of the display mode . . . . .	13	Index . . . . .	51
Initial settings . . . . .	14	<b>Making/Answering Calls</b>	
<b>Making/Answering Calls</b>		Making calls . . . . .	15
Making calls . . . . .	15	Answering calls . . . . .	15
Answering calls . . . . .	15	Useful features during a call . . . . .	16
Useful features during a call . . . . .	16	<b>Shared Phonebook</b>	
<b>Shared Phonebook</b>		Shared phonebook . . . . .	18
Shared phonebook . . . . .	18	<b>Programming</b>	
<b>Programming</b>		Programmable settings . . . . .	20
Programmable settings . . . . .	20	Special programming . . . . .	25
Special programming . . . . .	25	Registering a unit . . . . .	28
Registering a unit . . . . .	28	<b>Call Display Service</b>	
<b>Call Display Service</b>		Using Call Display service . . . . .	29
Using Call Display service . . . . .	29	Caller list . . . . .	31
Caller list . . . . .	31	<b>Answering System</b>	
<b>Answering System</b>		Answering system . . . . .	33
Answering system . . . . .	33	Turning the answering system on/off . . . . .	33
Turning the answering system on/off . . . . .	33	Greeting message . . . . .	34
Greeting message . . . . .	34	Listening to messages using the base unit . . . . .	34
Listening to messages using the base unit . . . . .	34	Listening to messages using the handset . . . . .	35
Listening to messages using the handset . . . . .	35	Remote operation . . . . .	36
Remote operation . . . . .	36	Answering system settings . . . . .	37
Answering system settings . . . . .	37		

**Introduction**

**Model composition**

■ **KX-TG7411 series**

■ **KX-TG7431 series**

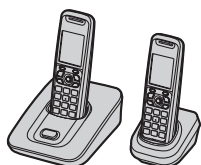

● Model shown is KX-TG7412.

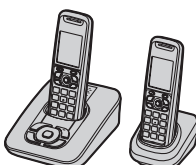

● Model shown is KX-TG7432.

Series	Model No.	Base unit	Handset	
		Part No.	Part No.	Quantity
KX-TG7411 series	KX-TG7412	KX-TG7411	KX-TGA740	2
	KX-TG7413	KX-TG7411	KX-TGA740	3
KX-TG7431 series	KX-TG7432	KX-TG7431	KX-TGA740	2
	KX-TG7433	KX-TG7431	KX-TGA740	3
	KX-TG7434	KX-TG7431	KX-TGA740	4

- The suffix (C) in the following model numbers will be omitted in these instructions: KX-TG7412C/KX-TG7413C/KX-TG7432C/KX-TG7433C/KX-TG7434C

**Feature differences**

Model No.	Answering system	Talking Call Display	Talking alert <sup>*1</sup>	Headset jack
KX-TG7411 series	—	—	—	●
KX-TG7431 series	●	●	●	●

\*1 Talking battery alert (page 10)/Talking alarm clock (page 25)

**Introduction**

**Accessory information**

**Supplied accessories**

No.	Accessory item/ Part number	Quantity		
		KX-TG7412 KX-TG7432	KX-TG7413 KX-TG7433	KX-TG7434
①	AC adaptor/PQLV219	2	3	4
②	Telephone line cord	1	1	1
③	Rechargeable batteries* <sup>1</sup> / HHR-65AAABU or N4DHYYY00002	4	6	8
④	Handset cover* <sup>2</sup>	2	3	4
⑤	Belt clip	2	3	4
⑥	Charger	1	2	3

\*1 See below for replacement battery information.

\*2 The handset cover comes attached to the handset.

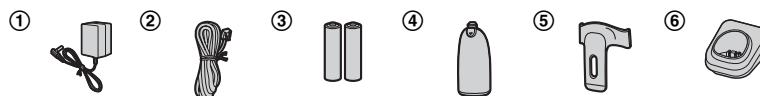

**Additional/replacement accessories**

Please contact your nearest Panasonic dealer for sales information.

Accessory item	Order number
Rechargeable batteries	HHR-4DPA* <sup>1</sup>
	Battery requirement: – Nickel metal hydride (Ni-MH) type battery – 2 AAA (R03) batteries for every handset
Headset	RP-TCA86, RP-TCA94, RP-TCA95



\*1 Replacement batteries may have a different capacity from that of the supplied batteries.

**Introduction****Expanding your phone system**

You can expand your phone system by registering optional handsets (6 max.) to a single base unit.

- Optional handsets may be a different colour from that of the supplied handsets.

**Optional handset feature overview**

Feature	KX-TGA740C	KX-TGA641C	KX-TGA840C
Handset			
Display colour/ size	Monochrome/ 2.1 inches	Monochrome/ 1.8 inches	Colour/2.0 inches
Control type	Joystick (Up/down/left/right)	Navigator key (Up/down)	Joystick (Up/down/left/right)
Temporary switch of the display mode (page 13)	●	–	●
Display mode (page 27)	●	–	●
Message list (page 35)	●	–	●
Wallpaper	–	–	●
Colour ID <sup>*1</sup>	–	–	●
LCD backlight <sup>*2</sup>	–	–	●

\*1 You can assign a different background colour to each phonebook entry. When a call is received from a caller stored in the phonebook, the assigned background colour is displayed.

\*2 You can select whether the handset display backlight is dimmed or turned off completely after being placed on the base unit or charger.

## Important Information

### For your safety

To prevent severe injury and loss of life/property, read this section carefully before using the product to ensure proper and safe operation of your product.

#### WARNING

##### Power connection

- Use only the power source marked on the product.
- Do not overload power outlets and extension cords. This can result in the risk of fire or electric shock.
- Completely insert the AC adaptor/power plug into the power outlet. Failure to do so may cause electric shock and/or excessive heat resulting in a fire.
- Regularly remove any dust, etc. from the AC adaptor/power plug by pulling it from the power outlet, then wiping with a dry cloth. Accumulated dust may cause an insulation defect from moisture, etc. resulting in a fire.
- Unplug the product from power outlets if it emits smoke, an abnormal smell, or makes an unusual noise. These conditions can cause fire or electric shock. Confirm that smoke has stopped emitting and contact an authorized service centre.
- Unplug from power outlets and never touch the inside of the product if its casing has been broken open.
- Never touch the plug with wet hands. Danger of electric shock exists.

##### Installation

- To prevent the risk of fire or electrical shock, do not expose the product to rain or any type of moisture.
- Do not place or use this product near automatically controlled devices such as automatic doors and fire alarms. Radio waves emitted from this product may cause such devices to malfunction resulting in an accident.
- Do not allow the AC adaptor or telephone line cord to be excessively pulled, bent or placed under heavy objects.

##### Operating safeguards

- Unplug the product from power outlets before cleaning. Do not use liquid or aerosol cleaners.
- Do not disassemble the product.
- Do not spill liquids (detergents, cleansers, etc.) onto the telephone line cord plug, or allow it to become wet at all. This may cause a fire. If the telephone line cord plug becomes wet, immediately pull it from the telephone wall jack, and do not use.

##### Medical

- Consult the manufacturer of any personal medical devices, such as pacemakers or hearing aids, to determine if they are adequately shielded from external RF (radio frequency) energy. (The product operates in the frequency range of 1.92 GHz to 1.93 GHz, and the RF transmission power is 115 mW (max..))
- Do not use the product in health care facilities if any regulations posted in the area instruct you not to do so. Hospitals or health care facilities may be using equipment that could be sensitive to external RF energy.

#### CAUTION

##### Installation and relocation

- Never install telephone wiring during an electrical storm.
- Never install telephone line jacks in wet locations unless the jack is specifically designed for wet locations.
- Never touch uninsulated telephone wires or terminals unless the telephone line has been disconnected at the network interface.
- Use caution when installing or modifying telephone lines.
- The AC adaptor is used as the main disconnect device. Ensure that the AC outlet is installed near the product and is easily accessible.
- This product is unable to make calls when:
  - the handset batteries need recharging or have failed.
  - there is a power failure.

## Important Information

### Battery

- We recommend using the batteries noted on page 4. **USE ONLY rechargeable Ni-MH batteries AAA (R03) size.**
- Do not mix old and new batteries.
- Do not open or mutilate the batteries. Released electrolyte from the batteries is corrosive and may cause burns or injury to the eyes or skin. The electrolyte is toxic and may be harmful if swallowed.
- Exercise care when handling the batteries. Do not allow conductive materials such as rings, bracelets, or keys to touch the batteries, otherwise a short circuit may cause the batteries and/or the conductive material to overheat and cause burns.
- Charge the batteries provided with or identified for use with this product only, in accordance with the instructions and limitations specified in this manual.
- Only use a compatible base unit (or charger) to charge the batteries. Do not tamper with the base unit (or charger). Failure to follow these instructions may cause the batteries to swell or explode.

### Attention:



A nickel metal hydride battery that is recyclable powers the product you have purchased.  
Please call 1-800-8-BATTERY (1-800-822-8837) for information on how to recycle this battery.

## Important safety instructions

When using your product, basic safety precautions should always be followed to reduce the risk of fire, electric shock, and injury to persons, including the following:

1. Do not use this product near water for example, near a bathtub, washbowl,

2. kitchen sink, or laundry tub, in a wet basement or near a swimming pool.
2. Avoid using a telephone (other than a cordless type) during an electrical storm. There may be a remote risk of electric shock from lightning.
3. Do not use the telephone to report a gas leak in the vicinity of the leak.
4. Use only the power cord and batteries indicated in this manual. Do not dispose of batteries in a fire. They may explode. Check with local codes for possible special disposal instructions.

### SAVE THESE INSTRUCTIONS

## For best performance

### Base unit location/avoiding noise

The base unit and other compatible Panasonic units use radio waves to communicate with each other.

- For maximum coverage and noise-free communications, place your base unit:
  - at a convenient, high, and central location with no obstructions between the handset and base unit in an indoor environment.
  - away from electronic appliances such as TVs, radios, personal computers, wireless devices, or other phones.
  - facing away from radio frequency transmitters, such as external antennas of mobile phone cell stations. (Avoid putting the base unit on a bay window or near a window.)
- Coverage and voice quality depends on the local environmental conditions.
- If the reception for a base unit location is not satisfactory, move the base unit to another location for better reception.

### Environment

- Keep the product away from electrical noise generating devices, such as fluorescent lamps and motors.
- The product should be kept free from excessive smoke, dust, high temperature, and vibration.
- The product should not be exposed to direct sunlight.
- Do not place heavy objects on top of the product.

### Important Information

- When you leave the product unused for a long period of time, unplug the product from the power outlet.
- The product should be kept away from heat sources such as heaters, kitchen stoves, etc. It should not be placed in rooms where the temperature is less than 0 °C (32 °F) or greater than 40 °C (104 °F). Damp basements should also be avoided.
- The maximum calling distance may be shortened when the product is used in the following places: Near obstacles such as hills, tunnels, underground, near metal objects such as wire fences, etc.
- Operating the product near electrical appliances may cause interference. Move away from the electrical appliances.

#### Routine care

- **Wipe the outer surface of the product with a soft moist cloth.**
- Do not use benzine, thinner, or any abrasive powder.

#### Notice for product disposal, transfer, or return

- This product can store your private/confidential information. To protect your privacy/confidentiality, we recommend that you erase information such as phonebook or caller list entries from the memory before you dispose of, transfer, or return the product.

### Specifications

- **Standard:**  
DECT 6.0 (Digital Enhanced Cordless Telecommunications 6.0)
- **Frequency range:**  
1.92 GHz to 1.93 GHz
- **RF transmission power:**  
115 mW (max.)
- **Power source:**  
120 V AC, 60 Hz
- **Power consumption:**  
**Base unit:**  
Standby: Approx. 1.1 W  
Maximum: Approx. 4.4 W  
**Charger:**  
Standby: Approx. 0.1 W  
Maximum: Approx. 2.6 W

#### Operating conditions:

0 °C – 40 °C (32 °F – 104 °F), 20 % – 80 % relative air humidity (dry)

#### Note:

- Design and specifications are subject to change without notice.
- The illustrations in these instructions may vary slightly from the actual product.

### Other information

**CAUTION:** Risk of explosion if battery is replaced by an incorrect type. Dispose of used batteries according to the instructions.

#### ENERGY STAR

As an ENERGY STAR® Partner, Panasonic has determined that this product meets the ENERGY STAR guidelines for energy efficiency. ENERGY STAR is a U.S. registered mark.





**Getting Started**

**Setting up**

**Connections**

- Use only the supplied Panasonic AC adaptor PQLV219.

■ **Base unit**

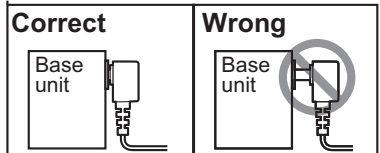
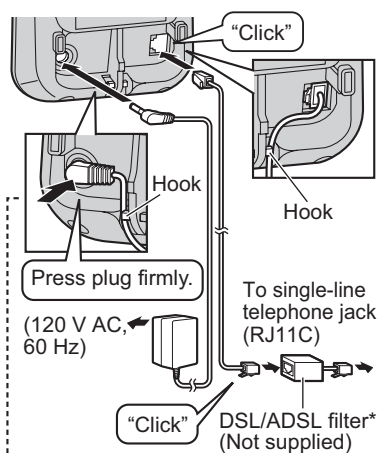

\*For DSL/ADSL service users

■ **Charger**

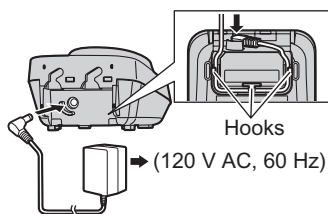

**Battery installation**

- USE ONLY Ni-MH batteries AAA (R03) size.
- Do NOT use Alkaline/Manganese/Ni-Cd batteries.
- Confirm correct polarities ( $\oplus$ ,  $\ominus$ ).

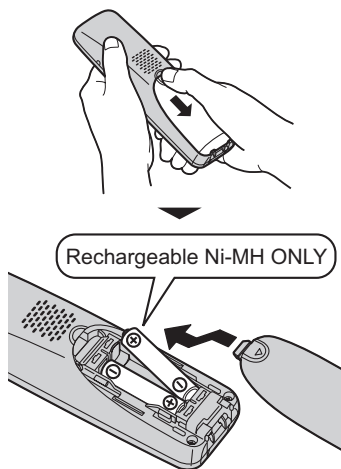

**Battery charge**

Charge for about 7 hours.

- When the batteries are fully charged, the charge indicator goes off.

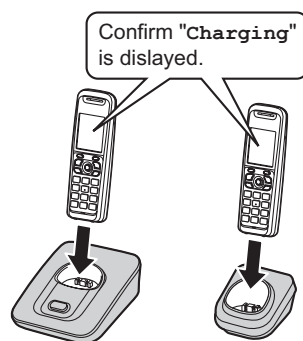

## Getting Started

### Note when setting up

#### Note for connections

- The AC adaptor must remain connected at all times. (It is normal for the adaptor to feel warm during use.)
- The AC adaptor should be connected to a vertically oriented or floor-mounted AC outlet. Do not connect the AC adaptor to a ceiling-mounted AC outlet, as the weight of the adaptor may cause it to become disconnected.

#### During a power failure

The unit will not work during a power failure. We recommend connecting a corded-type telephone (without AC adaptor) to the same telephone line or to the same telephone line jack using a T-adaptor.





#### Note for battery installation

- Use the supplied rechargeable batteries. For replacement, we recommend using the Panasonic rechargeable batteries noted on page 4, 7.
- Wipe the battery ends (⊕, ⊖) with a dry cloth.
- Avoid touching the battery ends (⊕, ⊖) or the unit contacts.

#### Note for battery charge

- It is normal for the handset to feel warm during charging.
- Clean the charge contacts of the handset, base unit, and charger with a soft and dry cloth once a month. Clean more often if the unit is exposed to grease, dust, or high humidity.

#### Battery level

Icon	Battery level
	High
	Medium
	Low
	Needs charging.
	Empty

#### Note:

- The batteries need to be charged if:
  - the handset alerts you with a voice announcement (**talking battery alert**) after you finish talking or listening to a message. (KX-TG7431 series: page 3)
  - the handset beeps while you are engaged in a call.
  - the handset beeps while you are operating the answering system remotely. (KX-TG7431 series: page 3)

#### Panasonic Ni-MH battery performance (supplied batteries)

Operation	Operating time
In continuous use	5 hours max.* <sup>1</sup>
Not in use (standby)	11 days max.

\*<sup>1</sup> When the clarity booster feature is turned on (page 17): 3 hours max.

#### Note:

- Actual battery performance depends on a combination of how often the handset is in use and how often it is not in use (standby).
- Even after the handset is fully charged, the handset can be left on the base unit or charger without any ill effect on the batteries.

## Getting Started

- The battery level may not be displayed correctly after you replace the batteries. In this case, place the handset on the base unit or charger and let it charge for at least 7 hours.

## Controls

### Handset

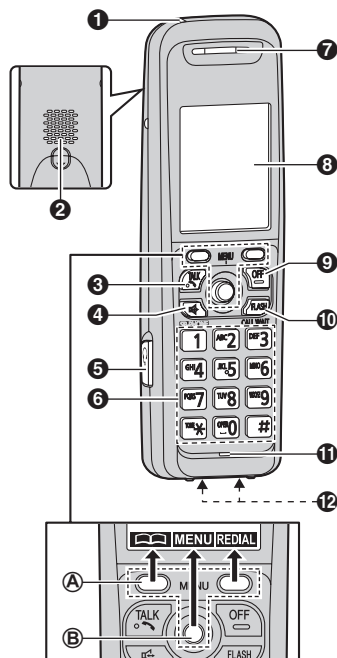

- 1** Charge indicator  
Ringer indicator  
Message indicator
- 2** Speaker
- 3** [↶] (TALK)
- 4** [☎] (SP-PHONE: Speakerphone)
- 5** Headset jack
- 6** Dial keypad ([\*]: TONE)

- 7** Receiver
- 8** Display
- 9** [OFF]
- 10** [FLASH] [CALL WAIT]
- 11** Microphone
- 12** Charge contacts

#### ■ Control type

##### Ⓐ Soft keys

The handset features 2 soft keys and a joystick. By pressing a soft key, or by pressing the centre of the joystick, you can select the feature shown directly above it on the display.

##### Ⓑ Joystick

By pushing the joystick ([▲], [▼], [←], or [→]) repeatedly, you can:

- scroll through (up, down, left, or right) various lists or items
- adjust the receiver or speaker volume (up or down) while talking

- As all multiple items cannot be displayed on screen at the same time, you can quickly search the desired item to move screens by pushing the joystick right or left, instead of scrolling down or up line by line (page 27).

## Getting Started

### Base unit

#### ■ KX-TG7411 series (page 3)

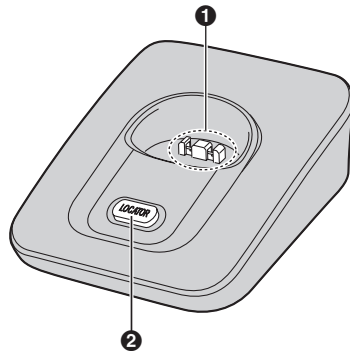

- 1 Charge contacts
- 2 [LOCATOR]

#### ■ KX-TG7431 series (page 3)

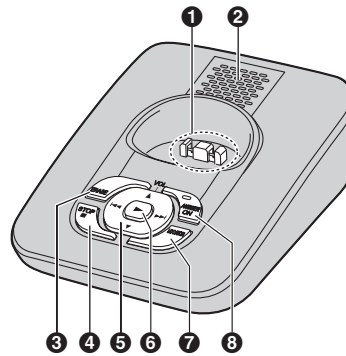

- 1 Charge contacts
- 2 Speaker
- 3 [ERASE]
- 4 [■] (STOP)
- 5 [▲]/[▼] (VOL.: Volume up/down)  
[⏮]/[⏭] (Repeat/Skip)
- 6 [▶] (Play)  
Message indicator
- 7 [LOCATOR]
- 8 [ANSWER ON]  
ANSWER ON indicator

**Getting Started**

**Display**

**Handset display items**

Item	Meaning
	Within range of a base unit
	Out of range of a base unit
<b>IN USE</b>	The line is in use. <ul style="list-style-type: none"> <li>When flashing:                             <ul style="list-style-type: none"> <li>The call is put on hold.</li> <li>The answering system is answering a call.*1</li> </ul> </li> <li>When flashing rapidly: An incoming call is now being received.</li> </ul>
	Speaker is on. (page 15)
	Ringer volume is off. (page 23)
	Night mode is on. (page 26)
<b>BOOST</b>	Clarity booster is on. (page 17)
	Alarm is on. (page 25)
	Handset number
	Battery level
	Blocked call (page 26)

\*1 KX-TG7431 series (page 3)

**Temporary switch of the display mode**

**Available for:**  
KX-TGA740C/KX-TGA840C handset

You can select to display either a single item or multiple items on one screen at a time for the following features:

- menu list, phonebook list, caller list, redial list, message list, and call block list
- handset top menu icons in function menu

The following icons are shown when you press down on the centre of the joystick in standby mode.

Icon	Feature
	Caller list
	Set date / time*1
	Answering device*2
	V.M. access
	Intercom
	Initial setting
	Customer support

\*1 KX-TG7411 series (page 3)

\*2 KX-TG7431 series (page 3)

You can temporarily switch the display mode as follows by pressing the right soft key shown when viewing the lists or selecting menu icons:

- **[MULTI]**: Multiple entries/all menu icons are shown on one screen at a time.
- **[SINGLE]**: An entry/a menu icon is shown on one screen in large characters at a time.

**Note:**

- You can set the unit to always show a single item or multiple items

## Getting Started

beforehand by selecting “**Single item**” or “**Multi items**” as the display mode setting (page 27).

- When “**Multi items**” is selected as the display mode, you can switch the screen to confirm the detailed information by pressing [**SINGLE**].

## Initial settings

### Symbol meaning:

Example: [▼]/[▲]: “off”

Push the joystick down or up to select the words in quotations.

## Display language

You can select either “**English**” or “**Français**” as the display language. The default setting is “**English**”.

- 1 [**MENU**] (centre of joystick) → [**#**][1][1][0]
- 2 [▼]/[▲]: Select the desired setting.
- 3 Press down the centre of the joystick to save. → [**OFF**]

## Voice guidance language

### Available for:

KX-TG7431 series (page 3)

You can select either “**English**” or “**Français**” as the voice guidance language of the answering system. This setting also determines the voice announcement language of the talking alarm clock and talking battery alert. The default setting is “**English**”.

- 1 [**MENU**] (centre of joystick) → [**#**][1][1][2]
- 2 [▼]/[▲]: Select the desired setting.
- 3 [**SAVE**] → [**OFF**]

## Dialing mode

If you cannot make calls, change this setting according to your telephone line service. The default setting is “**Tone**”.

“**Tone**”: For tone dial service.

“**Pulse**”: For rotary/pulse dial service.

- 1 [**MENU**] (centre of joystick) → [**#**][1][2][0]
- 2 [▼]/[▲]: Select the desired setting.
- 3 [**SAVE**] → [**OFF**]

## Date and time

- 1 [**MENU**] (centre of joystick) → [**#**][1][0][1]
- 2 Enter the current month, date, and year by selecting 2 digits for each.  
Example: July 15, 2009  
[0][7] [1][5] [0][9]
- 3 [**OK**]
- 4 Enter the current hour and minute (12-hour clock format) by selecting 2 digits for each.  
Example: 9:30  
[0][9] [3][0]
- 5 [**AM/PM**]: Select “**AM**” or “**PM**”.
- 6 [**SAVE**] → [**OFF**]

### Note:

- When English is selected as the display language, 12-hour clock format is used. When French is selected, 24-hour clock format is used.
- To correct a digit, push the joystick left or right to move the cursor to the digit, then make the correction.
- The date and time may be incorrect after a power failure. In this case, set the date and time again.

## Making/Answering Calls

### Making calls

- 1 Lift the handset and dial the phone number.
  - To correct a digit, press **[CLEAR]**.
- 2 Press **[↶]** or **[CALL]**.
- 3 When you finish talking, press **[OFF]** or place the handset on the base unit or charger.

### Using the speakerphone

- 1 Dial the phone number and press **[☎]**.
  - Speak alternately with the other party.
- 2 When you finish talking, press **[OFF]**.

#### Note:

- For best performance, use the speakerphone in a quiet environment.
- To switch back to the receiver, press **[↶]**.

### Adjusting the receiver or speaker volume

Push the joystick up or down repeatedly while talking.

### Making a call using the redial list

The last 5 phone numbers dialed are stored in the redial list (each 48 digits max.).

- 1 **[REDIAL]**
- 2 **[▼]/[▲]**: Select the desired phone number.
- 3 **[↶]**

### Erasing a number in the redial list

- 1 **[REDIAL]**
- 2 **[▼]/[▲]**: Select the desired phone number. → **[ERASE]**

- 3 **[▼]/[▲]**: "Yes" → **[SELECT]**
- 4 **[OFF]**

### Pause (for PBX/long distance service users)

A pause is sometimes required when making calls using a PBX or long distance service. When storing a calling card access number and/or PIN in the phonebook, a pause is also needed (page 19).

**Example:** If you need to dial the line access number "9" when making outside calls with a PBX:

- 1 **[9]** → **[PAUSE]**
- 2 Dial the phone number. → **[↶]**

#### Note:

- A 3.5 second pause is inserted each time **[PAUSE]** is pressed. Repeat as needed to create longer pauses.

### Answering calls

When a call is being received, the ringer indicator flashes rapidly.

- 1 Lift the handset and press **[↶]** or **[☎]** when the unit rings.
  - You can also answer the call by pressing any dial key from **[0]** to **[9]**, **[\*]**, or **[#]**. (**Any key answer feature**)
- 2 When you finish talking, press **[OFF]** or place the handset on the base unit or charger.

### Auto talk

You can answer calls simply by lifting the handset off the base unit or charger. You do not need to press **[↶]**. To turn this feature on, see page 22.

## Making/Answering Calls

### Adjusting the handset ringer volume

Push the joystick up or down repeatedly to select the desired volume while the handset is ringing for an incoming call.

#### Note:

- You can also program the handset ringer volume beforehand (page 23).

### Temporary handset ringer off

While the handset is ringing for a call, you can turn the ringer off temporarily by pressing [⏏].

### Adjusting the base unit ringer volume

**Available for:**  
KX-TG7431 series (page 3)

Press [▲] or [▼] repeatedly to select the desired volume.

- To turn the ringer off, press and hold [▼] until the unit beeps 2 times.

## Useful features during a call

### Hold

This feature allows you to put an outside call on hold.

- 1 Press [HOLD], then press [OFF] during an outside call.
- 2 To release hold, press [↶].
  - Another handset user can take the call by pressing [↶].

#### Note:

- If a call is kept on hold for more than 9 minutes, an alarm tone starts to sound and the ringer indicator on the handset flashes rapidly. After 1 additional minute on hold, the call is disconnected.

- If another phone is connected to the same line (page 10), you can also take the call by lifting its handset.

### Mute

While mute is turned on, you can hear the other party, but the other party cannot hear you.

- 1 Press [MUTE] during an outside call.
  - [MUTE] flashes.
- 2 To return to the conversation, press [MUTE] again.

#### Note:

- [MUTE] is a soft key visible on the handset display during a call.

### Flash

[FLASH] allows you to use the special features of your host PBX such as transferring an extension call, or accessing optional telephone services.

#### Note:

- To change the flash time, see page 23.

### For Call Waiting or Visual Call Waiting service users

To use Call Waiting, you must first subscribe to the Call Waiting service from your service provider/telephone company.

This feature allows you to receive calls while you are already talking on the phone. If you receive a call while on the phone, you will hear a Call Waiting tone.

**If you subscribe to both Call Display and Visual Call Waiting services**, the 2nd caller's information is displayed after you hear the Call Waiting tone on the handset.

- 1 Press [CALL WAIT] to answer the 2nd call.



## Making/Answering Calls

- 2** To switch between calls, press **[CALL WAIT]**.

**Note:**

- Please contact your service provider/telephone company for details and availability of this service in your area.

### Temporary tone dialing (for rotary/pulse service users)

You can temporarily switch the dialing mode to tone when you need to access touch-tone services (for example, answering services, telephone banking services, etc.).

Press **[\*]** (TONE) before entering access numbers which require tone dialing.

### Handset clarity booster

This feature can improve sound clarity when the handset is used in an area where there may be interference. During an outside call, this feature is turned on automatically when necessary.

- When this feature is turned on, **BOOST** is displayed.
- While this feature is turned on, the battery operating time is shortened (page 10).

### Call share

This feature allows you to join an existing outside call.

To join the conversation, press **[↶]** when the other handset is on an outside call.

**Note:**

- The possible number of participating parties depends on the series.
  - KX-TG7411 series (page 3):
    - 3 parties (including 1 outside party)
  - KX-TG7431 series (page 3):
    - 4 parties (including 1 outside party)

## Shared Phonebook

### Shared phonebook

The shared phonebook allows you to make calls without having to dial manually. Any handset registered to the base unit can use the shared phonebook. You can add 50 names and phone numbers to the shared phonebook.

#### Important:

- Only 1 person can access the shared phonebook at a time.
- Call Display subscribers can use ringer ID features (page 30).

### Adding entries

- 1 **[ADD]**
- 2 **[ADD]**
- 3 Enter the party's name (16 characters max.). → **[OK]**
- 4 Enter the phone number (32 digits max.). → **[OK]**
  - If you do not need to assign the ringer ID, go to step 7.
- 5 **[v]/[▲]**: "Set Ringer ID" → **[SELECT]**
- 6 **[v]/[▲]**: Select the desired setting (page 30). → **[OK]**
- 7 **[SAVE]**
  - To add other entries, repeat from step 2.
- 8 **[OFF]**

#### Note:

- If you select "No Ringer ID" (default), the handset uses the ringer tone you selected on page 23 when a call is received from that caller.
- When you assign the ringer ID to an entry in the shared phonebook using one handset, it is applied for all handsets.

### Character table for entering names

Key	Character
[1]	& ' ( ) , - . / 1
[2]	a b c A B C 2
[3]	d e f D E F 3
[4]	g h i G H I 4
[5]	j k l J K L 5
[6]	m n o M N O 6
[7]	p q r s P Q R S 7
[8]	t u v T U V 8
[9]	w x y z W X Y Z 9
[0]	Space 0
[*]	*
[#]	#

- To enter another character that is located on the same dial key, first push the joystick right to move the cursor to the next space.

### Correcting a mistake

Use the joystick to move the cursor to the character or number you want to erase, then press **[CLEAR]**. Enter the appropriate character or number.

- Press and hold **[CLEAR]** to erase all characters or numbers.

### Finding and calling a phonebook entry

#### Scrolling through all entries

- 1 **[v]/[▲]**: Select the desired entry.
- 2 **[v]/[▲]**: Select the desired entry.
- 3

## Shared Phonebook

### Searching by first character (alphabetically)

- 1 **[☞]**
- 2 Press the dial key ([0] – [9], [\*], or [#]) which contains the character you are searching for (page 18).
  - Press the same dial key repeatedly to display the first entry corresponding to each character located on that dial key.
  - If there is no entry corresponding to the character you selected, the next entry is displayed.
- 3 **[▼]/[▲]**: Scroll through the phonebook if necessary.
- 4 **[↶]**

### Editing entries

- 1 Find the desired entry (page 18).  
→ **[EDIT]**
- 2 **[▼]/[▲]**: Select the information you want to edit.
  - **To change the name or phone number:**  
**[▼]/[▲]**: Select the name or phone number. → **[SELECT]**  
→ Edit the information (page 18). → **[OK]**
  - **To change the ringer ID:**  
**[▼]/[▲]**: Select the current ringer ID. → **[SELECT]** → Select the desired setting. → **[OK]**
    - To turn the ringer ID off, select “No Ringer ID”.
- 3 **[SAVE]** → **[OFF]**

### Erasing entries

- 1 Find the desired entry (page 18).
- 2 **[ERASE]**
- 3 **[▼]/[▲]**: “Yes” → **[SELECT]** → **[OFF]**

### Chain dial

This feature allows you to dial phone numbers in the phonebook while you are on a call. This feature can be used, for example, to dial a calling card access number or bank account PIN that you have stored in the phonebook, without having to dial manually.

- 1 During an outside call, press **[☞]**.
- 2 **[▼]/[▲]**: Select the desired entry.
- 3 Press **[CALL]** to dial the number.

#### Note:

- When storing a calling card access number and your PIN in the phonebook as one phonebook entry, press **[PAUSE]** to add pauses after the number and PIN as necessary (page 15).
- If you have rotary/pulse service, you need to press **[\*]** (TONE) before pressing **[☞]** in step 1 to change the dialing mode temporarily to tone.

## Programming

### Programmable settings

You can customize the unit by programming the following features using the handset.

To access the features, there are 2 methods:

- scrolling through the display menus (page 20)
- using the direct commands (page 22)
- Direct command is the main method used in these operating instructions.

#### Programming by scrolling through the display menus

- 1 **[MENU]** (centre of joystick)
- 2 Select the desired top-menu by pushing the joystick in any direction. → **[SELECT]**
- 3 Push the joystick down or up to select the desired item in sub-menu 1. → **[SELECT]**
  - In some cases, you may need to select from sub-menu 2. → **[SELECT]**
- 4 Push the joystick down or up to select the desired setting. → **[SAVE]**
  - This step may vary depending on the feature being programmed.
  - To exit the operation, press **[OFF]**.

**Note:**

- See page 22 for the default settings.

Main menu	Sub-menu 1	Sub-menu 2	Page	
Caller list →)	-	-	31	
Set date / time ⊖ (KX-TG7411 series: page 3)	Date and time* <sup>1</sup>	-	14	
	Alarm	-	25	
	Time adjust* <sup>1</sup>	-	-	
Answering device ☎ (KX-TG7431 series: page 3)	Message list	-	35	
	Play new msg.	-	35	
	Play all msg.	-	35	
	Erase all msg.* <sup>1</sup>	-	36	
	Greeting	Record greeting* <sup>1</sup>		34
		Check greeting		34
		Pre-recorded* <sup>1</sup>		34
	Settings	Ring count* <sup>1</sup>		37
		Recording time* <sup>1</sup>		38
		Remote code* <sup>1</sup>		36
Answer on* <sup>1</sup>	-		33	
Answer off* <sup>1</sup>	-		33	

**Programming**

Main menu	Sub-menu 1	Sub-menu 2	Page
V.M. access ✉	-	-	40
Intercom ☎	-	-	41
Initial setting ⚙	Ringer setting	Ringer volume	-
		Ringer tone	-
		Night mode - On / Off - Start / End	25
	Set date / time	Date and time <sup>*1</sup>	14
		Alarm	25
		Time adjust <sup>*1</sup>	-
	Talking CallerID (KX-TG7431 series: page 3)	Handset	29
		Base unit <sup>*1</sup>	
	Voice Mail	Store V.M. no. <sup>*1</sup>	39
		VM tone detect <sup>*1</sup>	39
	Call block <sup>*1</sup>	-	26
	Message alert	-	38
	Display setting	Display mode	27
		LCD contrast	-
	Key tone	-	-
	Auto talk	-	15
	Set tel line	Set dial mode <sup>*1</sup>	14
		Set flash time <sup>*1</sup>	16
		Set line mode <sup>*1</sup>	-
		C.WTG options <sup>*1</sup>	30
Registration	Register handset	28	
	Deregistration	28	
Change language	Display	14	
	Voice prompt <sup>*1</sup> (KX-TG7431 series: page 3)	14	
Customer support 🗺	-	-	-

\*1 If you program these settings using one of the handsets, you do not need to program the same item using another handset.

## Programming

### Programming using the direct commands

- 1 **[MENU]** (centre of joystick) → **[⇐]**
- 2 Enter the desired feature code.
- 3 Enter the desired setting code. → **[SAVE]**
  - This step may vary depending on the feature being programmed.
  - To exit the operation, press **[OFF]**.

#### Note:

- In the following table, < > indicates the default settings.

Feature	Feature code	Setting code	System setting <sup>*1</sup>	Page
Alarm	[7][2][0]	[1]: Once [2]: Daily [0]: <Off>	–	25
Auto talk <sup>*2</sup>	[2][0][0]	[1]: On [0]: <Off>	–	15
Block w/o num. (Block calls without phone number)	[2][4][0]	[1]: On [0]: <Off>	●	27
Call block	[2][1][7]	–	●	26
Caller list	[2][1][3]	–	–	31
Customer support <sup>*3</sup>	[6][8][0]	–	–	–
C.WTG options (Call Waiting Deluxe options)	[2][1][5]	[1]: On [0]: <Off>	●	30
Date and time	[1][0][1]	–	●	14
Deregistration	[1][3][1]	–	–	28
Display (Change language)	[1][1][0]	[1]: <English> [2]: Français	–	14
Display mode	[1][9][2]	[1]: <Multi items> [0]: Single item	–	27
Intercom	[2][7][4]	–	–	41
Key tone <sup>*4</sup>	[1][6][5]	[1]: <On> [0]: Off	–	–
LCD contrast (Display contrast)	[1][4][5]	[1]–[6]: Level 1–6 <3>	–	–
Message alert	[3][4][0]	[1]: <On> [0]: Off	–	38
Night mode (On/Off)	[2][3][8]	[1]: On [0]: <Off>	–	26
Night mode (Start/End)	[2][3][7]	<11:00 PM/06:00 AM>	–	26

**Programming**

Feature	Feature code	Setting code	System setting <sup>*1</sup>	Page
Register handset	[1][3][0]	-	-	28
Ringer tone <sup>*5, *6</sup> (Handset)	[1][6][1]	[1]-[3]: Tone <1>-3 [4]-[7]: Melody 1-4	-	-
Ringer volume <sup>*7</sup> (Handset)	[1][6][0]	[1]: Low [2]: Medium [3]: <High> [0]: Off	-	-
Set dial mode	[1][2][0]	[1]: Pulse [2]: <Tone>	●	14
Set flash time <sup>*8</sup>	[1][2][1]	[0]: 900ms [1]: <700ms> [2]: 600ms [3]: 400ms [4]: 300ms [5]: 250ms [*]: 200ms [†]: 160ms [6]: 110ms [7]: 100ms [8]: 90ms [9]: 80ms	●	16
Set line mode <sup>*9</sup>	[1][2][2]	[1]: A [2]: <B>	●	-
Store V.M. no. (V.M.: Voice Mail)	[3][3][1]	-	●	39
Time adjust <sup>*10</sup> (Call Display subscribers only)	[2][2][6]	[1]: <Caller ID auto> [0]: Manual	●	-
V.M. access (V.M.: Voice Mail)	[3][3][0]	-	-	40
VM tone detect (V.M.: Voice Mail)	[3][3][2]	[1]: <On> [0]: Off	●	39

For the Talking Call Display/Answering system (KX-TG7431 series: page 3)

Feature	Feature code	Setting code	System setting <sup>*1</sup>	Page
Answer off	[3][2][8]	-	●	33
Answer on	[3][2][7]	-	●	33
Check greeting	[3][0][3]	-	-	34
Erase all msg. (msg.: messages)	[3][2][5]	-	●	36
Message list	[3][2][9]	-	-	35
Play all msg. (msg.: messages)	[3][2][4]	-	-	35
Play new msg. (msg.: messages)	[3][2][3]	-	-	35
Pre-recorded (Reset to pre-recorded greeting)	[3][0][4]	-	●	34

### Programming

Feature	Feature code	Setting code	System setting <sup>*1</sup>	Page
Record greeting	[3][0][2]	-	●	34
Recording time	[3][0][5]	[1]: 1min [2]: 2min [3]: <3min> [0]: Greeting only	●	38
Remote code	[3][0][6]	<111>	●	36
Ring count	[2][1][1]	[2]-[7]: 2-7 rings <4> [0]: Toll saver	●	37
Talking CallerID (Talking Call Display) (Handset)	[1][6][2]	[1]: <On> [0]: Off	-	29
Talking CallerID (Base unit)	[*][1][6][2]	[1]: On [0]: <Off>	●	29
Voice prompt (Change language)	[1][1][2]	[1]: <English> [2]: Français	●	14

\*1 If "System setting" column is checked, you do not need to program the same item using another handset.

\*2 If you subscribe to a Call Display service and want to view the caller's information after lifting up the handset to answer a call, turn off this feature.

\*3 The handset can display the Internet address where you can download the operating instructions or get further information for this product, using your computer.

\*4 Turn this feature off if you prefer not to hear key tones while you are dialing or pressing any keys, including confirmation tones and error tones.

\*5 If you subscribe to a distinctive ring service, select a tone (tone 1 to 3). If you select a melody, you cannot distinguish lines by their ringers.

\*6 If you select one of the melody ringer tones, the ringer tone continues to play for several seconds even if the caller has already hung up. You may either hear a dial tone or no one on the line when you answer the call.

\*7 When the ringer volume is turned off,  $\mathcal{R}$  is displayed and the handset does not ring for outside calls.

However even when the ringer volume is set to off, the handset rings at the low level for alarm (page 25), and intercom calls, and paging (page 41).

\*8 The flash time depends on your telephone exchange or host PBX. Contact your PBX supplier if necessary.

\*9 Generally, the line mode setting should not be adjusted. If **INUSE** is not displayed when another phone connected to the same line is in use, you need to change the line mode to "A".

\*10 This feature allows the unit to automatically adjust the date and time setting when caller information is received. To use this feature, set the date and time first.



**Programming**

**Special programming**

**Alarm**

You can set one of 2 different alarm options (once or daily) at a time for each handset. An alarm sounds at the set time for 1 minute. The following alarm sounds are available:

■ **KX-TG7411 series: page 3**

You can choose an alarm sound from 3 tones and 4 melodies.

■ **KX-TG7431 series: page 3**

– “**Tone/Melody**”: You can choose an alarm sound from 3 tones and 4 melodies.

– “**Voice**”: You can choose one of the 7 pre-recorded announcements:

- “Good morning”
- “It’s time for dinner”
- “It’s time for lunch”
- “It’s time for the game”
- “It’s time for your meeting”
- “It’s time to pick up the children”
- “Happy birthday”

The unit makes the selected announcement at the set time (**talking alarm clock**).

**Important:**

- Set the date and time beforehand (page 14).

**1** **[MENU]** (centre of joystick) → **[#][7][2][0]**

**2** **[v]/[▲]**: Select the desired alarm option. → **[SELECT]**

<b>Off</b>	Turns alarm off. Go to step 6.
<b>Once</b>	An alarm sounds once at the set time. Enter the desired month, date, and year. → <b>[OK]</b>

<b>Daily</b>	An alarm sounds daily at the set time.
--------------	--

- 3** Set the desired time. → **[OK]**
- KX-TG7411 series (page 3) users skip to step 5.
- 4** **[v]/[▲]**: Select “**Tone/Melody**” or “**Voice**”. → **[SELECT]**
- 5** **[v]/[▲]**: Select the desired item. → **[SAVE]**
- If you set a tone or melody, we recommend selecting a different one for outside calls.
- 6** **[OFF]**
- When the alarm is set, **Ⓞ** is displayed.

**Note:**

- To stop the alarm, press any dial key or place the handset on the base unit or charger.
- When the handset is in use, the alarm will not sound until the handset is in standby mode.
- If the talking alarm clock is set at the same time for two or more handsets, the first handset makes the announcement, while the other handsets only sound the tone. (KX-TG7431 series: page 3)
- If the other unit is in use at the set time, the handsets sound the tone instead of the selected announcement. (KX-TG7431 series: page 3)
- If you select “**Once**”, the setting changes to “**Off**” after the alarm sounds.

**Night mode**

Night mode allows you to select a period of time during which the handset will not ring for outside calls. This feature is useful for time periods when you do not want to be disturbed, for example, while

## Programming

sleeping. Night mode can be set for each handset.

### Important:

- Set the date and time beforehand (page 14).
- We recommend turning the base unit ringer off (page 16) and call screening off (page 33) in addition to turning the night mode on. (KX-TG7431 series: page 3)
- If you have set the alarm, the alarm sounds even if the night mode is turned on.

### Turning night mode on/off

- 1 **[MENU]** (centre of joystick) → **[#][2][3][8]**
- 2 **[▼]/[▲]**: Select “On” or “Off”. → **[SAVE]**
  - If you select “Off”, press **[OFF]** to exit.
- 3 Enter the desired hour and minute you wish to start this feature.
- 4 **[AM/PM]**: Select “AM” or “PM”. → **[OK]**
- 5 Enter the desired hour and minute you wish to end this feature.
- 6 **[AM/PM]**: Select “AM” or “PM”.
- 7 **[SAVE]** → **[OFF]**
  - When the night mode is set,  is displayed.

### Note:

- To correct a digit, push the joystick left or right to move the cursor to the digit, then make the correction.

### Changing the start and end time

- 1 **[MENU]** (centre of joystick) → **[#][2][3][7]**
- 2 Continue from step 3, “Turning night mode on/off”, page 26.

## Call block (Call Display subscribers only)

This feature allows the unit to reject calls when:

- the unit receives a call from a phone number stored in the call block list as unwanted (“Storing unwanted callers”, page 26).
- the unit receives a call without phone number (“Block calls without phone number”, page 27).

When a call is received, the unit rings for a short time while the caller is being identified. If the unit recognizes the call as unwanted, “**Caller blocked**” is displayed and the unit sends out a busy tone to the caller, and then disconnects the call.

### Important:

- When the unit receives a call from a number that is stored in the call block list or a call without a recognized phone number, the call is logged in the caller list (page 31) with  after the call is disconnected.

### Storing unwanted callers

You can store up to 30 phone numbers in the call block list by using the caller list or by entering the numbers directly.

### Important:

- You must store the phone number with an area code (10 digits) in the call block list.

### From the caller list:

- 1 **[MENU]** (centre of joystick) → **[#][2][1][3]**
- 2 **[▼]/[▲]**: Select the entry to be blocked. → **[SELECT]**
  - To edit the number, press **[EDIT]** repeatedly until the phone number is shown in the 10-digit format.

## Programming

- 3 [SAVE]
- 4 [▼]/[▲]: "Call block" → [SELECT]
- 5 [▼]/[▲]: "Yes" → [SELECT] → [OFF]

### ■ By entering phone numbers:

- 1 [MENU] (centre of joystick) → [♯][2][1][7] → [ADD]
- 2 Enter the phone number (32 digits max.).
  - To erase a digit, press [CLEAR].
- 3 [SAVE] → [OFF]

### Block calls without phone number

You can reject a call without phone number including "Unavailable Name & No.", "Private caller", or "Long distance".

- 1 [MENU] (centre of joystick) → [♯][2][4][0]
- 2 [▼]/[▲]: Select the desired setting. → [SAVE] → [OFF]

### Viewing/editing/erasing call block numbers

- 1 [MENU] (centre of joystick) → [♯][2][1][7]
- 2 [▼]/[▲]: Select the desired entry.
  - To exit, press [OFF].
- 3 Proceed with the desired operation.
  - **Editing a number:**  
[EDIT] → Edit the phone number. → [SAVE] → [OFF]
  - **Erasing a number:**  
[ERASE] → [▼]/[▲]: "Yes" → [SELECT] → [OFF]

### Note:

- When editing, press the desired dial key to add, [CLEAR] to erase.
- When viewing, [w/o NUM] appears if the block calls without phone number

feature is turned on. To turn the feature off: [w/o NUM] → [▼] → [SAVE] → [OFF]

## Display mode

**Available for:**  
KX-TGA740C/KX-TGA840C handset

You can select to display either a single item or multiple items on one screen at a time for the following features:

- menu list, phonebook list, caller list, redial list, message list, and call block list
- handset top menu icons in function menu

Select the desired setting:

- "Multi items": Multiple entries/all menu icons are shown on one screen at a time.
- "Single item": An entry/a menu icon is shown on one screen in large characters at a time.

The default setting is "Multi items".

- 1 [MENU] (centre of joystick) → [♯][1][9][2]
- 2 [▼]/[▲]: Select the desired setting. → [SAVE]
- 3 [OFF]

### Note:

- When [MULTI] or [SINGLE] is displayed as a right soft key on the handset, you can temporarily switch the display mode by pressing [MULTI] or [SINGLE] (page 13).
- When [MULTI] or "Multi items" is selected as the display mode, you can move screens by pushing the joystick right or left, without scrolling down or up through the list:
  - Push the joystick right to go to the next screen.

## Programming

- Push the joystick left to return to the previous screen.

### Registering a unit

#### Operating additional units

##### Additional handsets

Up to 6 handsets can be registered to the base unit.

##### Important:

- See page 5 for information on the available model.

#### Registering a handset to a base unit

The supplied handset and base unit are pre-registered. If for some reason the handset is not registered to the base unit, re-register the handset.

- 1 Handset:**  
[MENU] (centre of joystick) →  
[#][1][3][0]
- 2 Base unit:**
  - **KX-TG7411 series: page 3**  
Press and hold [LOCATOR] for about 4 seconds. (No registration tone)
  - **KX-TG7431 series: page 3**  
Press and hold [LOCATOR] for about 4 seconds until the registration tone sounds.
  - If all registered handsets start ringing, press the same button to stop. Then repeat this step.
  - The next step must be completed within 90 seconds.
- 3 Handset:**  
Press [OK], then wait until a long beep sounds.

#### 4 [OFF]

##### Note:

- While registering, “**Base regtr'ing**” (Base registering) is displayed on all registered handsets.
- When you purchase an additional handset, refer to the additional handset’s installation manual for registration.

#### Deregistering a handset

A handset can cancel its own registration (or the registration of another handset) that is stored to the base unit. This allows the handset to end its wireless connection with the system.

- 1 [MENU]** (centre of joystick) →  
[#][1][3][1]
- 2 [3][3][5]** → [OK]
- 3** Select the handset you want to cancel by pressing the desired handset number.
- 4 [▼]/[▲]:** “Yes” → [SELECT]

## Call Display Service

### Using Call Display service

#### Important:

- This unit is Call Display compatible. To use Call Display features, you must subscribe to a Call Display service. Contact your service provider/telephone company for details.

#### Call Display features

When an outside call is being received, the caller's name and phone number are displayed.

Caller information for the last 50 callers is logged in the caller list from the most recent call to the oldest.

- If the unit cannot receive caller information, the following is displayed:
  - “**Unavailable Name & No.**”/“**Unavailable**”<sup>\*1</sup>: The caller dials from an area which does not provide a Call Display service.
  - “**Private caller**”: The caller requests not to send caller information.
  - “**Long distance**”: The caller makes a long distance call.
- If the unit is connected to a PBX system, caller information may not be properly received. Contact your PBX supplier.

\*1 Shown while viewing the caller list.

#### Missed calls

If a call is not answered, the unit treats it as a missed call. The display shows “**Missed call**”. This lets you know if you should view the caller list to see who called while you were away.

#### Phonebook name display

When caller information is received and it matches a phone number stored in the phonebook, the stored name in the phonebook is displayed and logged in the caller list.

#### Talking Call Display

**Available for:**  
KX-TG7431 series (page 3)

This feature lets you know who is calling without looking at the display.

To use this feature, you must:

- subscribe to a Call Display service of your service provider/telephone company.
- turn this feature on (page 24).

When caller information is received, the handsets and base unit announce the caller's name or phone number received from your service provider/telephone company following every ring.

- Name pronunciation may vary. This feature may not pronounce all names correctly.
- Call Display service has a limit of how many characters can be displayed. If the caller's name is too long, the handset may not be able to display or announce the entire name.
- The announcement is heard at the same level as the ringer volume (page 16, 23).
- If you turn on the answering system and set the number of rings “2” (page 37), the unit does not announce the caller information. If “**Toll saver**” is selected and there is a new message, the unit does not announce the caller information.
- When you receive a call while on the phone, the 2nd caller's name is not announced even if you subscribe to

## Call Display Service

both Call Display and Visual Call Waiting services.

### Phonebook name announcement

When caller information is received and it matches a phone number stored in the phonebook, the stored name in the phonebook is announced.

### Ringer ID

This feature can help you identify who is calling by using different ringers for different callers stored in the phonebook (page 18). You can assign a different ringer to each phonebook entry. When a call is received from a caller stored in the phonebook, the assigned ringer rings after the caller information is displayed.

### For Call Waiting Deluxe service users

To use Call Waiting Deluxe, you must subscribe to Call Waiting Deluxe service of your service provider/telephone company.

This feature not only allows your handset to display the 2nd caller's information, but also offers you a variety of ways to deal with the 2nd call.

#### Important:

- Please contact your service provider/telephone company for details and availability of this service in your area.
- This feature must be turned on before it can be used.

#### To turn Call Waiting Deluxe on/off

To use Call Waiting Deluxe, you must turn this feature on. The default setting is "Off".

- 1 **[MENU]** → **[#][2][1][5]**
- 2 **[▼]/[▲]**: Select the desired setting.
- 3 **[SAVE]** → **[OFF]**

### Call Waiting Deluxe service options

When a 2nd call is received, you can choose how to handle the call by selecting an option shown on the handset display.

#### Note:

- Your service provider/telephone company may not offer all of the options (page 30).

Displayed option	Function
<b>Answer</b>	Answers the waiting call, while keeping the 1st call on hold.
<b>Hold</b>	Holds the waiting call. The caller will hear the pre-recorded hold message played by your service provider/telephone company.
<b>Announce</b>	The caller will hear the pre-recorded busy message played by your service provider/telephone company (for example, "We are not available now.") and will then be disconnected.

### Call Display Service

Displayed option	Function
<b>Forward</b>	Forwards the waiting call to the Voice Mail service provided by your service provider/ telephone company. You must subscribe to Voice Mail service to use this function.
<b>Drop</b>	Disconnects (drops) the current call and answers the waiting call.
<b>Conference</b>	Answers the waiting call and combines it with the current call to make a conference call (3-party call).
<b>Return</b>	Returns to the waiting caller while keeping the current call on hold.
<b>Drop caller1</b>	Disconnects (drops) the 1st call during a conference call.
<b>Drop caller2</b>	Disconnects (drops) the 2nd call during a conference call.

- After selecting “Answer”, “Hold”, or “Conference”, you can select another option. → **[FLASH]** → **[▼]/[▲]**: Select the desired option. → **[SELECT]**

**Note:**

- To exit from the option menu, wait for 20 seconds.

### Caller list

**Important:**

- Only 1 person can access the caller list at a time.
- Make sure the unit's date and time setting is correct (page 14).

### Viewing the caller list and calling back

- 1** **[MENU]** (centre of joystick) → **[#][2][1][3]**
- 2** Push the joystick down to search from the most recent call, or push the joystick up to search from the oldest call.
  - You can see detailed information about the caller by pressing **[SINGLE]** when “Multi items” is selected as the display mode (page 27).
- 3** To call back, press **[↶]**. To exit, press **[OFF]**.

**Note:**

- If the entry has already been viewed or answered, “✓” is displayed, even if it was viewed or answered using another handset.

**To use Call Waiting Deluxe service**

- 1** When you hear a Call Waiting tone during an outside call, press **[FLASH]**.
  - The option menu is displayed.
- 2** **[▼]/[▲]**: Select the desired option. → **[SELECT]**

## Call Display Service

### Editing a caller's phone number before calling back

You can edit a phone number in the caller list by adding the long distance code "1" or removing its area code.

- 1 **[MENU]** (centre of joystick) → **[#][2][1][3]**
- 2 **[▼]/[▲]**: Select the desired entry. → **[SELECT]**
- 3 Press **[EDIT]** repeatedly until the phone number is shown in the desired format.

- ① 1 – Area code – Local phone number

**Example:**

1-555-321-5555

- ② Local phone number

**Example:**

321-5555

- ③ Area code – Local phone number

**Example:**

555-321-5555

### 4 **[↶]**

**Note:**

- The number edited in step 3 will not be saved in the caller list.

### Erasing selected caller information

- 1 **[MENU]** (centre of joystick) → **[#][2][1][3]**
- 2 **[▼]/[▲]**: Select the desired entry.
- 3 **[ERASE]** → **[▼]/[▲]**: "Yes" → **[SELECT]** → **[OFF]**

### Erasing all caller information

- 1 **[MENU]** (centre of joystick) → **[#][2][1][3]**
- 2 **[ERASE]** → **[▼]/[▲]**: "Yes" → **[SELECT]**

### Storing caller information in the phonebook

- 1 **[MENU]** (centre of joystick) → **[#][2][1][3]**
- 2 **[▼]/[▲]**: Select the desired entry. → **[SELECT]**
  - To edit the number, press **[EDIT]** repeatedly until the phone number is shown in the desired format.
- 3 **[SAVE]**
- 4 **[▼]/[▲]**: "Phonebook" → **[SELECT]**
- 5 Continue from step 2, "Editing entries", page 19.



## Answering System

### Answering system

**Available for:**  
KX-TG7431 series (page 3)

The answering system can answer and record calls for you when you are unavailable to answer the phone. You can also set the unit to play a greeting message but not to record caller messages by selecting “**Greeting only**” as the recording time setting (page 38).

**Important:**

- Only 1 person can access the answering system (listen to messages, record a greeting message, etc.) at a time.
- When callers leave messages, the unit records the day and time of each message. Make sure the date and time have been set correctly (page 14).

### Memory capacity

The total recording capacity (including your greeting message) is about 16 minutes. A maximum of 64 messages can be recorded.

**Note:**

- If message memory becomes full:
  - “**Messages full**” is shown on the handset display.
  - The ANSWER ON indicator on the base unit flashes rapidly when the answering system is turned on.
- When the message memory becomes full:
  - If you use the pre-recorded greeting message, the unit automatically switches to another pre-recorded greeting message asking callers to call again later.

- If you recorded your own greeting message, the same message is still announced to callers even though their messages are not recorded.

### Turning the answering system on/off

**Base unit**

Press **[ANSWER ON]** to turn on/off the answering system.

**Handset**

■ **To turn on:**

- 1 **[MENU]** (centre of joystick) →  
**[#][3][2][7]**
- 2 **[OFF]**

■ **To turn off:**

- 1 **[MENU]** (centre of joystick) →  
**[#][3][2][8]**
- 2 **[OFF]**

**Note for base unit and handset:**

- When the answering system is turned on, the ANSWER ON indicator on the base unit lights up.

### Call screening

While a caller is leaving a message, you can listen to the call through the base unit's speaker. To adjust the speaker volume, press **[▲]** or **[▼]** repeatedly. You can answer the call by pressing **[↶]** on the handset.

**Turning off the call screening feature**

While screening a call, press and hold **[▼]** until the sound goes off.

**Note:**

- If you adjust the speaker volume while listening to messages, the speaker

## Answering System

volume for call screening is turned on again.

### Greeting message

When the unit answers a call, a greeting message is played to callers.

You can use either:

- your own greeting message
- a pre-recorded greeting message

### Recording your greeting message using the handset

- 1 **[MENU]** (centre of joystick) → **[#][3][0][2]**
- 2 **[▼]/[▲]**: “yes” → **[SELECT]**
- 3 After a beep sounds, speak clearly (2 minutes max.).
- 4 Press **[STOP]** to stop recording.
- 5 **[OFF]**

### Using a pre-recorded greeting message

The unit provides 2 pre-recorded greeting messages:

- If you erase or do not record your own greeting message, the unit plays a pre-recorded greeting asking callers to leave a message.
- If the message recording time (page 38) is set to “**Greeting only**”, callers’ messages are not recorded and the unit plays a different pre-recorded greeting message asking callers to call again.

### Erasing your greeting message (Resetting to a pre-recorded greeting message)

If you want to use a pre-recorded greeting message once you record your

own greeting message, you need to erase your own greeting message.

- 1 **[MENU]** (centre of joystick) → **[#][3][0][4]**
- 2 **[YES]** → **[OFF]**

### Playing back the greeting message

- 1 **[MENU]** (centre of joystick) → **[#][3][0][3]**
- 2 **[OFF]**

### Listening to messages using the base unit

When new messages have been recorded, the message indicator on the base unit flashes.

Press **[▶]**.

- If new messages have been recorded, the base unit plays back new messages.
- If there are no new messages, the base unit plays back all messages.

### Operating the answering system during playback

Key	Operation
<b>[▲]</b> or <b>[▼]</b>	Adjust the speaker volume
<b>[◀◀]</b>	Repeat message <sup>*1</sup>
<b>[▶▶]</b>	Skip message
<b>[■]</b> (STOP)	Pause message - To resume playback, press <b>[▶]</b> . - To stop playback completely, press <b>[■]</b> (STOP) again.

## Answering System

Key	Operation
[ERASE]	Erase currently playing message

\*1 If pressed within the first 5 seconds of a message, the previous message is played.

### Erasing all messages

Press [ERASE] 2 times while the unit is not in use.

### Listening to messages using the handset

When new messages have been recorded:

- "New message" is displayed.
- The message indicator on the handset flashes slowly if the message alert feature is turned on (page 38).

- 1 [MENU] (centre of joystick) → [PLAY]
  - If new messages have been recorded, the handset plays back new messages.
  - If there are no new messages, the handset plays back all messages.

- 2 When finished, press [OFF].

#### Note:

- In step 1, you can also perform the desired operation.
  - To listen to new messages:  
[MENU] (centre of joystick) → [≡][3][2][3]
  - To listen to all messages:  
[MENU] (centre of joystick) → [≡][3][2][4]
- To switch to the receiver, press [↶].

### Listening to messages from the message list

**Available for:**  
KX-TGA740C/KX-TGA840C handset

You can select the item to play back.

- 1 [MENU] (centre of joystick) → [≡][3][2][9]
- 2 [▼]/[▲]: Select the desired item from the message list. → [PLAY]
  - You can erase the selected message as follows:  
[ERASE] → [▼]/[▲]: "Yes" → [SELECT]
- 3 When finished, press [OFF].

#### Note:

- If the item has already been heard, "✓" is displayed, even if it was heard using another handset.
- If the unit cannot receive caller information, "Msg." is displayed in the message list.

### Operating the answering system during playback

Key	Operation
[▼] or [▲] (joystick)	Adjust the receiver/speaker volume
[1] or [◀] (joystick)	Repeat message <sup>*1, *2</sup>
[2] or [▶] (joystick)	Skip message <sup>*3</sup>
[STOP]	Stop playback
[ERASE]	Erase currently playing message

\*1 If pressed within the first 5 seconds of a message, the previous message is played.

## Answering System

\*2 When you play a message from the message list, the currently playing message is played back from the beginning.

\*3 When you play a message from the message list, the unit stops message playback and the display goes back to the message list.

### Calling back (Call Display subscribers only)

If caller information is received for the call, you can call the caller back while listening to a message.

- 1 Press **[SELECT]** during playback.
  - To edit the number before calling back, press **[EDIT]** repeatedly until the phone number is shown in the desired format (page 32).

### 2 **[↶]**

### Erasing all messages

- 1 **[MENU]** (centre of joystick) → **[#][3][2][5]**
- 2 **[▼]/[▲]**: “Yes” → **[SELECT]** → **[OFF]**

## Remote operation

Using a touch-tone phone, you can call your phone number from outside and access the unit to listen to messages or change answering system settings. The unit's voice guidance prompts you to press certain dial keys to perform different operations.

### Remote access code

A 3-digit remote access code must be entered when operating the answering system remotely. This code prevents unauthorized parties from listening to

your messages remotely. The default setting is “111”.

- 1 **[MENU]** (centre of joystick) → **[#][3][0][6]**
- 2 Enter the desired 3-digit remote access code. → **[SAVE]** → **[OFF]**

### Using the answering system remotely

- 1 Dial your phone number from a touch-tone phone.
- 2 After the greeting message starts, enter your remote access code.
  - The unit plays back new messages.
- 3 Follow the voice guidance prompts as necessary or control the unit using remote commands (page 37).
- 4 When finished, hang up.

#### Note:

- You can also leave a message just as any outside caller can. After the greeting message starts, press **[\*]** to skip the greeting message and record your message after the beep.

### Voice guidance

During remote operation, the unit's voice guidance starts and prompts you to press **[1]** to perform a specific operation, or press **[2]** to listen to more available operations. Operations are presented by voice guidance in the following order:

- Play back all messages
- Play back new messages
- Record your message
- Erase all messages

## Answering System

### Note:

- If you do not press any dial keys within 10 seconds after a voice guidance prompt, the unit disconnects your call.

### Remote commands

You can press dial keys to access certain answering system functions without waiting for the voice guidance to prompt you.

Key	Operation
[1]	Repeat message (during playback) <sup>*1</sup>
[2]	Skip message (during playback)
[4]	Play new messages
[5]	Play all messages
[9]	Stop playback <sup>*2</sup>
[0]	Turn answering system off
[*][4]	Erase currently playing message
[*][5]	Erase all messages

\*1 If pressed within the first 5 seconds of a message, the previous message is played.

\*2 To resume operation, enter a remote command within 15 seconds, or the voice guidance starts.

### Turning on the answering system remotely

If the answering system is off, you can turn it on remotely.

- 1 Dial your phone number from a touch-tone phone.
- 2 Let the phone ring 15 times.
  - A long beep is heard.

- 3 Enter your remote access code within 10 seconds after the long beep.
  - The greeting message is played back.
  - You can either hang up, or enter your remote access code again and begin remote operation (page 36).

## Answering system settings

### Number of rings before the unit answers a call

You can change the number of times the phone rings “**Ring count**” before the unit answers calls. You can select 2 to 7 rings, or “**Toll saver**”. The default setting is “4”.

“**Toll saver**”: The unit’s answering system answers at the end of the 2nd ring when new messages have been recorded, or at the end of the 4th ring when there are no new messages. If you call your phone from outside to listen to new messages (page 36), you know that there are no new messages when the phone rings for the 3rd time. You can then hang up without being charged for the call.

- 1 **[MENU]** (centre of joystick) → **[#][2][1][1]**
- 2 **[▼]/[▲]**: Select the desired setting. → **[SAVE]** → **[OFF]**

### For Voice Mail service subscribers

If you subscribe to a flat-rate service package that includes Call Display, Call Waiting, Voice Mail, and unlimited local/regional/long distance calls, please note the following:

## Answering System

- To use the Voice Mail service provided by your service provider/telephone company rather than the unit's answering system, turn off the answering system (page 33).
- To use this unit's answering system rather than the Voice Mail service provided by your service provider/telephone company, please contact your service provider/telephone company to deactivate your Voice Mail service.

If your service provider/telephone company cannot do this:

- Set this unit's "Ring count" setting so that this unit's answering system answers calls before the Voice Mail service of your service provider/telephone company does. It is necessary to check the number of rings required to activate the Voice Mail service provided by your service provider/telephone company before changing this setting.
- Change the number of rings of the Voice Mail service so that the answering system can answer the call first. To do so, contact your service provider/telephone company.

### Caller's recording time

You can change the maximum message recording time allotted to each caller.

You can also select "Greeting only" which sets the unit to greet callers but not record messages. The default setting is "3min".

- 1 **[MENU]** (centre of joystick) → **[#][3][0][5]**
- 2 **[▼]/[▲]**: Select the desired setting. → **[SAVE]** → **[OFF]**

### Note:

- If you want to select "Greeting only", follow the steps above and press **[0]** in step 2.
- When you select "Greeting only":
  - If you do not record your own message, the unit will play the pre-recorded greeting-only message asking callers to call again later.
  - If you use your own message, record the greeting-only message asking callers to call again later (page 34).

### Message alert

You can select whether or not the message indicator on the handset flashes slowly when new messages are recorded. The default setting is "On".

### Important:

- If you stored the Voice Mail access number (page 39), the message indicator also flashes for newly recorded Voice Mail messages (page 40).

- 1 **[MENU]** (centre of joystick) → **[#][3][4][0]**
- 2 **[▼]/[▲]**: Select the desired setting. → **[SAVE]** → **[OFF]**

### Note:

- While message alert is on, battery operating time is shortened (page 10).

## Voice Mail Service

### Voice Mail service

Voice Mail is an automatic answering service offered by your service provider/telephone company. After you subscribe to this service, your service provider/telephone company's Voice Mail system answers calls for you when you are unavailable to answer the phone or when your line is busy. Messages are recorded by your service provider/telephone company, not your telephone. Please contact your service provider/telephone company for details of this service.

#### Important:

- To use the Voice Mail service provided by your service provider/telephone company rather than the unit's answering system, turn off the answering system (page 33). For details, see page 37 (KX-TG7431 series: page 3).
- You need to store the Voice Mail access number to activate the message alert feature (page 38) for Voice Mail service.

### Storing the Voice Mail (VM) access number

In order to listen to your Voice Mail messages, you must dial your service provider/telephone company's Voice Mail access number. Once you have stored your Voice Mail access number, you can dial it automatically (page 40).

- 1 **[MENU]** (centre of joystick) → **[#][3][3][1]**
- 2 Enter your access number (32 digits max.). → **[SAVE]** → **[OFF]**

#### Note:

- When storing your Voice Mail access number and your mailbox password,

press **[PAUSE]** to add pauses (page 15) between the access number and the password as necessary. Contact your service provider/telephone company for the required pause time.

#### Example:

1-222-333-4444	PPPP	8888
VM access	Pauses	Password
number		

#### To erase the Voice Mail access number

- 1 **[MENU]** (centre of joystick) → **[#][3][3][1]**
- 2 Press and hold **[CLEAR]** until all digits are erased. → **[SAVE]** → **[OFF]**

### Voice Mail (VM) tone detection

Your service provider/telephone company sends special signals (sometimes called "Voice Mail tones" or "stutter tones") to the unit to let you know you have new Voice Mail messages. If you hear a series of dial tones followed by a continuous dial tone after you press **[↶]**, you have new Voice Mail messages. Minutes after you hang up a call or after the phone stops ringing, your unit checks the phone line to see if new Voice Mail messages have been recorded.

Turn this feature off when:

- You do not subscribe to Voice Mail service.
- Your service provider/telephone company does not send Voice Mail tones.
- Your phone is connected to a PBX.

If you are not sure which setting is required, contact your service provider/telephone company.

## Voice Mail Service

### Turning VM tone detection on/off

The default setting is "on".

- 1 **[MENU]** (centre of joystick) → **[\*][3][3][2]**
- 2 **[v]/[▲]**: Select the desired setting.  
→ **[SAVE]** → **[OFF]**

### Listening to Voice Mail messages

The unit lets you know that you have new Voice Mail messages in the following ways:

- "New Voice Mail" is displayed on the handset if message indication service is available.
- The message indicator on the handset flashes slowly if message alert feature is turned on ("Message alert", page 38).

- 1 Press **[↶]**, then press **[VM]** within 15 seconds.  
OR  
**[MENU]** (centre of joystick) → **[\*][3][3][0]**
  - The speakerphone turns on.
- 2 Follow the pre-recorded instructions.
- 3 When finished, press **[OFF]**.

#### Note:

- If **[VM]** is not displayed, the Voice Mail access number has not been stored. Store the number (page 39).
- If the handset still indicates there are new messages even after you have listened to all new messages, turn it off by pressing and holding **[OFF]** until the handset beeps.
- If your Voice Mail service uses Voice Mail tones and a message is over 3 minutes long, the handset may not indicate new messages.

- If your Voice Mail service uses Voice Mail tones, the tones are heard from any phone connected to the same line. If you want to use another phone to listen to Voice Mail messages, you have to dial your access number manually.



## Intercom

Intercom calls can be made between handsets.

### Note:

- If you receive an outside call while talking on the intercom, you hear 2 tones. To answer the call, press **[OFF]**, then press **[↶]**.
- When paging unit(s), the paged unit(s) beeps for 1 minute.

### Making an intercom call

- 1 **[MENU]** (centre of joystick) → **[#][2][7][4]**
- 2 **[▼]/[▲]**: Select the desired unit. → **[CALL]**
  - To stop paging, press **[OFF]**.
- 3 When you finish talking, press **[OFF]**.

### Answering an intercom call

- 1 Press **[↶]** to answer the page.
- 2 When you finish talking, press **[OFF]**.

## Handset locator

You can locate a misplaced handset by pressing **[LOCATOR]** on the base unit. To stop paging, press it again or **[OFF]** on the handset.

## Transferring calls, conference calls

Outside calls can be transferred or a conference call with an outside party can be made between 2 handsets.

**Example:** When handset 1 transfers a call to handset 2 and/or establishes a conference call.

- 1 **Handset 1:**  
During an outside call, press **[HOLD]** to put the call on hold.
- 2 **Handset 1:**  
**[▼]/[▲]**: Select the desired unit. → **[CALL]**
  - If the paged party does not answer, press **[↶]** to return to the outside call.
- 3 **Handset 2:**  
Press **[↶]** to answer the page.
  - Handset 2 can talk with handset 1.
- 4 Proceed with the desired operation.
  - **To transfer the call:**
    - ① **Handset 1:**  
Press **[OFF]**.
    - ② **Handset 2:**  
Press **[↶]**.
      - Handset 2 can talk with the outside caller.
  - **To establish a conference call:**

**Handset 1:**  
Press **[CONF]**.

    - To leave the conference, press **[OFF]**. The other parties can continue the conversation.
    - To put the outside call on hold, press **[HOLD]**. To resume the conference, press **[CONF]**.

## Useful Information

### Belt clip

- To attach      ■ To remove



### Wall mounting

- 1 Drive the screws (not supplied) into the wall.

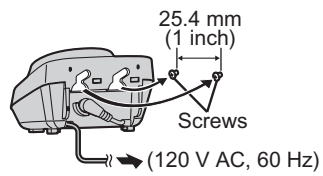

- 2 Mount the charger (1), then slide it down (2) and to the right (3) until it is secure.

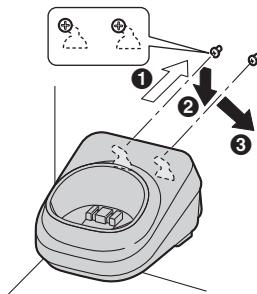

**Useful Information**

**Error messages**

If the unit detects a problem, one of the following messages is shown on the display.

Display message	Cause/solution
<b>Busy</b> or <b>System busy. Try again later.</b>	<ul style="list-style-type: none"> <li>● The called unit is in use.</li> <li>● Other units are in use and the system is busy. Try again later.</li> <li>● The handset you are using is too far from the base unit. Move closer and try again.</li> <li>● The handset's registration may have been cancelled. Re-register the handset (page 28).</li> </ul>
<b>Check tel line</b>	<ul style="list-style-type: none"> <li>● The supplied telephone line cord has not been connected yet or not connected properly. Check the connections (page 9).</li> </ul>
<b>Error!!</b>	<ul style="list-style-type: none"> <li>● The handset's registration has failed. Move the handset and base unit away from all electrical appliances and try again.</li> </ul>
<b>Invalid</b>	<ul style="list-style-type: none"> <li>● There is no handset registered to the base unit matching the handset number you entered.</li> <li>● The handset is not registered to the base unit. Register the handset (page 28).</li> </ul>
<b>No link to base. Reconnect main base AC adaptor.</b>	<ul style="list-style-type: none"> <li>● The handset has lost communication with the base unit. Move closer to the base unit and try again.</li> <li>● Unplug the base unit's AC adaptor to reset the unit. Reconnect the adaptor and try again.</li> <li>● The handset's registration may have been cancelled. Re-register the handset (page 28).</li> </ul>
<b>Requires subscription to Caller ID.</b>	<ul style="list-style-type: none"> <li>● You must subscribe to a Call Display service. Once you receive caller information after subscribing to a Call Display service, this message will not be displayed.</li> </ul>
<b>Store V.M. no.</b>	<ul style="list-style-type: none"> <li>● You have not stored the Voice Mail access number. Store the number (page 39).</li> </ul>
<b>Use rechargeable battery.</b>	<ul style="list-style-type: none"> <li>● A wrong type of battery such as Alkaline or Manganese was inserted. Use only the rechargeable Ni-MH batteries noted on page 4, 7.</li> </ul>

## Useful Information

### Troubleshooting

If you still have difficulties after following the instructions in this section, disconnect the base unit's AC adaptor, then reconnect the base unit's AC adaptor. Remove the batteries from the handset, and then insert the batteries into the handset again.

#### General use

Problem	Cause/solution
The unit does not work.	<ul style="list-style-type: none"> <li>• Make sure the batteries are installed correctly (page 9).</li> <li>• Fully charge the batteries (page 9).</li> <li>• Check the connections (page 9).</li> <li>• Unplug the base unit's AC adaptor to reset the unit. Reconnect the adaptor and try again.</li> <li>• The handset has not been registered to the base unit. Register the handset (page 28).</li> </ul>
I cannot hear a dial tone.	<ul style="list-style-type: none"> <li>• The base unit's AC adaptor or telephone line cord is not connected. Check the connections.</li> <li>• If you are using a splitter to connect the unit, remove the splitter and connect the unit to the wall jack directly. If the unit operates properly, check the splitter.</li> <li>• Disconnect the base unit from the telephone line and connect the line to a known working telephone. If the working telephone operates properly, contact our service personnel to have the unit repaired. If the working telephone does not operate properly, contact your service provider/telephone company.</li> </ul>
The indicator on the handset flashes slowly.	<ul style="list-style-type: none"> <li>• New messages have been recorded. Listen to the new messages (page 35).<sup>*1</sup></li> <li>• New Voice Mail messages have been recorded. Listen to the new Voice Mail Messages (page 40).</li> </ul>

\*1 KX-TG7431 series: page 3



#### Programmable settings

Problem	Cause/solution
I have changed the display language to a language I cannot read.	<ul style="list-style-type: none"> <li>• Change the display language (page 14).</li> </ul>

**Useful Information**

Problem	Cause/solution
While programming, the handset starts to ring.	<ul style="list-style-type: none"> <li>• A call is being received. Answer the call and start again after hanging up.</li> </ul>
I cannot register a handset to a base unit.	<ul style="list-style-type: none"> <li>• The maximum number of handsets (6) is already registered to the base unit. Cancel unused handset registrations from the base unit (page 28).</li> <li>• Place the handset and the base unit away from other electrical appliances.</li> </ul>

**Battery recharge**

Problem	Cause/solution
The handset beeps and/or  flashes.	<ul style="list-style-type: none"> <li>• Battery charge is low. Fully charge the batteries (page 9).</li> </ul>
I fully charged the batteries, but  still flashes or  is displayed.	<ul style="list-style-type: none"> <li>• Clean the charge contacts and charge again (page 10).</li> <li>• It is time to replace the batteries (page 9).</li> </ul>
I fully charged the batteries, but the operating time seems to be shorter.	<ul style="list-style-type: none"> <li>• Clean the battery ends (+, -) and the charge contacts with a dry cloth and charge again.</li> </ul>

**Making/answering calls, intercom**

Problem	Cause/solution
 is displayed.	<ul style="list-style-type: none"> <li>• The handset is too far from the base unit. Move closer.</li> <li>• The base unit's AC adaptor is not properly connected. Reconnect AC adaptor to the base unit.</li> <li>• You are using the handset or base unit in an area with high electrical interference. Re-position the base unit and use the handset away from sources of interference.</li> <li>• The handset is not registered to the base unit. Register it (page 28).</li> </ul>
Noise is heard, sound cuts in and out.	<ul style="list-style-type: none"> <li>• You are using the handset or base unit in an area with high electrical interference. Re-position the base unit and use the handset away from sources of interference.</li> <li>• Move closer to the base unit.</li> <li>• If you use a DSL/ADSL service, we recommend connecting a DSL/ADSL filter between the base unit and the telephone line jack. Contact your DSL/ADSL provider for details.</li> </ul>

**Useful Information**

<b>Problem</b>	<b>Cause/solution</b>
The handset does not ring.	<ul style="list-style-type: none"> <li>• The ringer volume is turned off. Adjust the ringer volume (page 23).</li> <li>• Night mode is turned on. Turn it off (page 26).</li> </ul>
The base unit does not ring.*1	<ul style="list-style-type: none"> <li>• The ringer volume is turned off. Adjust the ringer volume (page 16).</li> </ul>
I cannot make a call.	<ul style="list-style-type: none"> <li>• The dialing mode may be set incorrectly. Change the setting (page 14).</li> <li>• The handset is too far from the base unit. Move closer and try again.</li> </ul>
I cannot make long distance calls.	<ul style="list-style-type: none"> <li>• Make sure that you have long distance service.</li> </ul>

\*1 KX-TG7431 series: page 3

**Call Display/Talking Call Display\*1**

<b>Problem</b>	<b>Cause/solution</b>
Caller information is not displayed.	<ul style="list-style-type: none"> <li>• You must subscribe to Call Display service. Contact your service provider/telephone company for details.</li> <li>• If your unit is connected to any additional telephone equipment such as a Call Display box or cordless telephone line jack, plug the unit directly into the wall jack.</li> <li>• If you use a DSL/ADSL service, we recommend connecting a DSL/ADSL filter between the base unit and the telephone line jack. Contact your DSL/ADSL provider for details.</li> <li>• The name display service may not be available in some areas. Contact your service provider/telephone company for details.</li> <li>• Other telephone equipment may be interfering with this unit. Disconnect the other equipment and try again.</li> </ul>
Caller information is displayed or announced late.*1	<ul style="list-style-type: none"> <li>• Depending on your service provider/telephone company, the unit may display or announce the caller's information at the 2nd ring or later.</li> <li>• Move closer to the base unit.</li> </ul>

**Useful Information**

<b>Problem</b>	<b>Cause/solution</b>
Caller information is not announced.*1	<ul style="list-style-type: none"> <li>• The handset or base unit's ringer volume is turned off. Adjust it (page 16, 23).</li> <li>• The Talking Call Display feature is turned off. Turn it on (page 24).</li> <li>• The number of rings for the answering system is set to "2" or "Toll saver". Select a different setting (page 37).</li> </ul>
I cannot dial the phone number edited in the caller list.	<ul style="list-style-type: none"> <li>• The phone number you dialed might have been edited incorrectly (for example, the long distance "1" or the area code is missing). Edit the phone number with another pattern (page 32).</li> </ul>
Time on the unit has shifted.	<ul style="list-style-type: none"> <li>• Incorrect time information from incoming Call Display changes the time. Set the time adjustment to "Manual" (off) (page 23).</li> </ul>
The 2nd caller's information is not displayed during an outside call. (Visual Call Waiting feature does not function.)	<ul style="list-style-type: none"> <li>• In order to use Call Display, Call Waiting, or Visual Call Waiting, you must first contact your service provider/telephone company and subscribe to the desired service. After subscribing, you may need to contact your service provider/telephone company again to activate this specific service, even if you already subscribed to both Call Display and Visual Call Waiting services.</li> </ul>

\*1 KX-TG7431 series: page 3

**Answering system (KX-TG7431 series: page 3)**

<b>Problem</b>	<b>Cause/solution</b>
The unit does not record new messages.	<ul style="list-style-type: none"> <li>• The answering system is turned off. Turn it on (page 33).</li> <li>• The message memory is full. Erase unnecessary messages (page 35).</li> <li>• The recording time is set to "Greeting only". Change the setting (page 38).</li> <li>• If you subscribe to a Voice Mail service, messages are recorded by your service provider/telephone company, not your telephone. Change the unit's number of rings setting or contact your service provider/telephone company (page 37).</li> </ul>

**Useful Information**

<b>Problem</b>	<b>Cause/solution</b>
I cannot operate the answering system.	<ul style="list-style-type: none"> <li>Someone is using the unit. Wait for the other user to finish.</li> <li>A caller is leaving a message. Wait for the caller to finish.</li> <li>The handset is too far from the base unit. Move closer.</li> </ul>
I cannot operate the answering system remotely.	<ul style="list-style-type: none"> <li>You are entering the wrong remote access code. If you forgot the remote access code, store a new remote access code (page 36).</li> <li>Press each key firmly.</li> <li>The answering system is turned off. Turn it on (page 37).</li> <li>You are using a rotary/pulse telephone. Try again using a touch-tone phone.</li> </ul>
While recording a greeting message or listening to messages, the unit rings and the operation stops.	<ul style="list-style-type: none"> <li>A call is being received. Answer the call and try again later.</li> </ul>

**Liquid damage**

<b>Problem</b>	<b>Cause/solution</b>
Liquid or other form of moisture has entered the handset/base unit.	<ul style="list-style-type: none"> <li>Disconnect the AC adaptor and telephone line cord from the base unit. Remove the batteries from the handset and leave to dry for at least 3 days. After the handset/base unit are completely dry, reconnect the AC adaptor and telephone line cord. Insert the batteries and charge fully before use. If the unit does not work properly, contact an authorized service centre.</li> </ul>

**Caution:**

- To avoid permanent damage, do not use a microwave oven to speed up the drying process.



*Useful Information*

**Industry Canada Notices and other information**

**NOTICE:**

This equipment meets the applicable Industry Canada Terminal Equipment Technical Specifications. This is confirmed by the registration number. The abbreviation, "IC:", before the registration number signifies that registration was performed based on a Declaration of Conformity indicating that Industry Canada technical specifications were met. It does not imply that Industry Canada approved the equipment. And, the term "IC:" signifies that Industry Canada radio technical specifications were met.

Before installing this equipment, users should ensure that it is permissible to be connected to the facilities of the local telecommunications company. The equipment must also be installed using an acceptable method of connection. The customer should be aware that compliance with the above conditions may not prevent degradation of service in some situations.

Repairs to certified equipment should be coordinated by a representative designated by the supplier. Any repairs or alterations made by the user to this equipment, or equipment malfunctions, may give the telecommunications company cause to request the user to disconnect the equipment.

Users should ensure, for their own protection, that the electrical ground connections of the power utility, telephone lines and internal metallic water pipe system, if present, are connected together. This precaution may be particularly important in rural areas.

**Caution:**

Users should not attempt to make such connections themselves, but should contact the appropriate electric inspection authority, or electrician, as appropriate.

**NOTICE:**

The **Ringer Equivalence Number (REN)** assigned to each terminal device provides an indication of the maximum number of terminals allowed to be connected to a telephone interface.

The termination on an interface may consist of any combination of devices subject only to the

requirement that the sum of the Ringer Equivalence Numbers of all the devices does not exceed 5.

The Ringer Equivalence Number (REN) of this unit: (found on the bottom of the unit).

**NOTICE:**

Operation is subject to the following two conditions: (1) this device may not cause interference, and (2) this device must accept any interference, including interference that may cause undesired operation of the device.

Privacy of communications may not be ensured when using this telephone.

Some cordless telephones operate at frequencies that may cause interference to nearby TVs and VCRs. To minimize or prevent such interference, the base of the cordless telephone should not be placed near, or on top of, a TV or VCR. If interference is experienced, move the cordless telephone further away from the TV or VCR. This will often reduce, or eliminate, interference.

**RF Exposure Warning:**

- This product complies with IC radiation exposure limits set forth for an uncontrolled environment.
- To comply with IC RF exposure requirements, the base unit must be installed and operated 20 cm (8 inches) or more between product and all person's body (excluding extremities of hands, wrist and feet).
- This product may not be collocated or operated in conjunction with any other antenna or transmitter.
- The handset may be carried and operated with only the specific provided belt-clip. Other non-tested belt-clips or similar body-worn accessories may not comply and must be avoided.

## Useful Information

# Warranty

### Panasonic Canada Inc.

5770 Ambler Drive, Mississauga, Ontario L4W 2T3

### PANASONIC PRODUCT - LIMITED WARRANTY EXCHANGE PROGRAM

Panasonic Canada Inc. warrants this product to be free from defects in material and workmanship and agrees to replace the product for a period as stated below from the date of original purchase.

**Telephone Accessory / Product      One (1) year**

#### **LIMITATIONS AND EXCLUSIONS**

This warranty does not apply to products purchased outside Canada or to any product which has been improperly installed, subjected to usage for which the product was not designed, misused or abused, damaged during shipping, or which has been altered or repaired in any way that affects the reliability or detracts from the performance, nor does it cover any product which is used commercially. This warranty is extended to the original end user purchaser only. A purchase receipt or other proof of date of original purchase is required before warranty service is performed.

**THIS EXPRESS, LIMITED WARRANTY IS IN LIEU OF ALL OTHER  
WARRANTIES, EXPRESS OR IMPLIED, INCLUDING ANY IMPLIED  
WARRANTIES OF MERCHANTABILITY AND FITNESS FOR A PARTICULAR  
PURPOSE.**

**IN NO EVENT WILL PANASONIC CANADA INC. BE LIABLE FOR ANY  
SPECIAL, INDIRECT OR CONSEQUENTIAL DAMAGES.**

In certain instances, some jurisdictions do not allow the exclusion or limitation of incidental or consequential damages, or the exclusion of implied warranties, so the above limitations and exclusions may not be applicable.

#### **CONTACT INFORMATION**

For product information and operation assistance, please contact:

Our Customer Care Centre: Telephone #: (905) 624-5505

1-800 #: 1-800-561-5505

Fax #: (905) 238-2360

Email link: "customer support" on [www.panasonic.ca](http://www.panasonic.ca)

For defective product exchange within the warranty period, please contact the original dealer or our Customer Care Centre.

**Index**

- A** Additional handset: 28
- Alarm: 25
- Answering calls: 15
- Answering system
  - Call screening: 33
  - Erasing messages: 35, 37
  - Greeting only: 38
  - Listening to messages: 34, 35, 36
  - Message list: 35
  - Number of rings: 37
  - Recording time: 38
  - Remote access code: 36
  - Remote operation: 36
  - Ring count: 37
  - Toll saver: 37
  - Turning on/off: 33, 37
- Auto talk: 15
- B** Battery: 9, 10
- Belt clip: 42
- Booster (Clarity booster): 17
- C** Call block: 26
- Call Display service: 29
- Caller list: 31
- Caller list edit: 32
- Call share: 17
- Call Waiting: 16
- Chain dial: 19
- Conference calls: 41
- Control type: 11
- Customer support: 22
- C.WTG (Call Waiting Deluxe): 30
- D** Date and time: 14
- Dialing mode: 14
- Direct commands: 22
- Display
  - Contrast: 22
  - Language: 14
  - Mode: 27
- E** Error messages: 43
- F** Flash: 16, 23
- G** Greeting message: 34
- H** Handset
  - Deregistration: 28
  - Locator: 41
  - Registration: 28
  - Hold: 16
- I** Intercom: 41
- K** Key tone: 22
- L** Line mode: 23
- M** Making calls: 15
- Missed calls: 29
- Mute: 16
- N** Night mode: 25
- P** Pause: 15
- Phonebook: 18
- Power failure: 10
- R** Redialing: 15
- Ringer tone: 23
- Rotary/pulse service: 17
- S** SP-PHONE (Speakerphone): 15
- T** Talking alarm clock: 25
- Talking battery alert: 10
- Talking Call Display: 29
- Temporary tone dialing: 17
- Time adjustment: 23
- Transferring calls: 41
- Troubleshooting: 44
- V** Visual Call Waiting: 16
- VM (Voice Mail): 39
- Voice guidance language: 14
- Voice Mail: 37, 39
- Volume
  - Receiver: 15
  - Ringer (Base unit): 16
  - Ringer (Handset): 16, 23
  - Speaker: 15
- W** Wall mounting: 42



**For your future reference**

We recommend keeping a record of the following information to assist with any repair under warranty.

Serial No.

Date of purchase

(found on the bottom of the base unit)

Name and address of dealer

Attach your purchase receipt here.

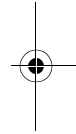
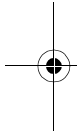

**Panasonic Canada Inc.**

5770 Ambler Drive, Mississauga, Ontario L4W 2T3

**Copyright:**

This material is copyrighted by Panasonic Communications Co., Ltd., and may be reproduced for internal use only. All other reproduction, in whole or in part, is prohibited without the written consent of Panasonic Communications Co., Ltd.

© Panasonic Communications Co., Ltd. 2009



\*TG7412C\*

**PNQX1643YA** CM0109DJ1039

